



HOODS AND
ASPIRATION HOBS

HOODS AND ASPIRATION HOBS

Every day, we strive to create
better products combining design,
performance and technology.

INDEX

8	Product Features
12	NIKOLATESLA
44	WALL
86	ISLAND
102	CEILING
120	SUSPENDED
140	DOWNDRAFT
146	BUILT-IN

167	GOOD TO KNOW
168	Weight
169	Performance
173	Learn More
175	Grease Filters
176	Odour Filters
180	Remote Motors
181	The Hood and You
184	Technical Information

WALL 44



ACUTA

85

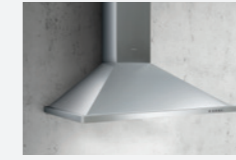

AQUAVITAE

84



DOLCE

76



ADÉLE

72



BIO

68



FILM

58



ALPHA

77



BLOOM-S

50



GALAXY

74



APLOMB

60



BLOOM

53



HAIKU

64



ASCENT

62



CLAIRE

75



IO AIR

56



ASCENT
URBAN

63



CRUISE

78



JOY

79

NIKOLATESLA 12



NIKOLATESLA
FIT

36



NIKOLATESLA
ONE

18



NIKOLATESLA
FLAME

30



NIKOLATESLA
PRIME
PRIME PLUS

26



NIKOLATESLA
LIBRA

20

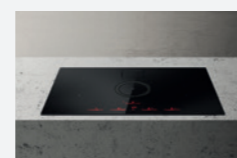

NIKOLATESLA
SWITCH

16

INDEX

WALL



LEAF

59



PLAT

47



STONE

82



MAJESTIC
NO DRIP

55



REEF A

81



TAMAYA HP

83



METEORITE

73



RULES

48



THIN

71

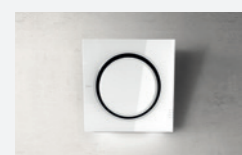

MINI IO

57



SHEEN-S

61



TONDA

83



NUANCE

54



SUPER PLAT

44



TRIBE A

80

ISLAND 86



ADÉLE ISLAND

98



METEORITE
ISLAND

96



TUBE PRO
ISLAND

101



BIO ISLAND

94



REEF A ISLAND

100



YIN

90



GALAXY
ISLAND

97



THIN
ISLAND

93



HAIKU ISLAND

88



TRIBE A
ISLAND

99

CEILING 102



CLOUD SEVEN

116



HILIGHT-X

114

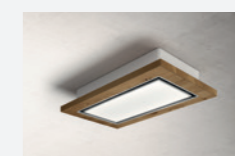

LULLABY

104



HILIGHT-GLS

112



ILLUSION

108



SKYDOME

106

INDEX

SUSPENDED 120



BELLE

125

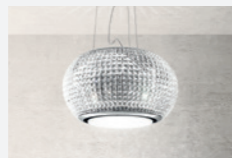

INTERSTELLAR

122



SIENNA

138



CELESTIAL

126



JUNO

136



SIENNA
URBAN

139



DIVA

124



JUNO URBAN

137

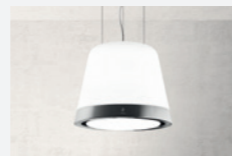

SUMMILUX

132



EASY

130



PEARL

123



TANDEM

135



FLOW

134



PIX

127

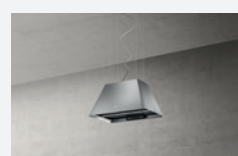

IKONA LIGHT

131

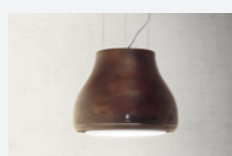

SHINING

133

BUILT-IN 146



BOXIN HE
BOXIN LUX
BOXIN

157



ERA LUX

153



KREA

161



BOXIN
NO DRIP

156



ERA STD

154



LANE

155



ELIBLOC

160

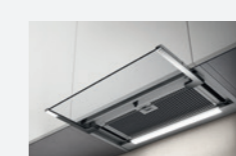

GLASS OUT

158



LEVER

163



ELITE 14

165



GLIDE

166



SKLOCK

164



ELITE 35

165



HIDDEN

159



SLEEK 2.0

151



ERA HE

152



INTEGRATA

162



SLEEK
2.0 @

148

DOWNDRAFT 140



GETUP

142



PANDORA

145

The company reserves the right to change the technical information and dimensions of the products included/ featured without notice.

EXTRACTION



CONNECTIVITY

Elica leads the way in appliance connectivity. We can control our Wi-Fi enabled products with the Elica app or through voice control assistants. To turn it on or off, adjust the extraction speed or intensity and the colour of the light, simply click the App or ask Alexis. The Elica App can also monitor the status of the hood and notify you of any cleaning operations that are required or filters that need replacing.



SPECIAL MATERIAL

In the quest for beautiful and eye-catching products materials play a key role. Whether selected to make the product blend in or stand out they should always be durable and easy to maintain. They are fundamental in the process of innovation and Elica selects materials in which practicality and aesthetic impact are combined in a perfect balance. The wide selection of finishes available offers choice to suit every setting.



BACK ASPIRATION

Hoods with this additional outlet offer greater installation flexibility. The aspiration function can be done by connecting the hood to ducting directly through the rear wall, avoiding the need for any visible ducting.



TOTAL INTEGRATION

The minimalist look is becoming increasingly popular in kitchens. The Total Integration products have been designed to be seamlessly integrated into the kitchen preserving the cleanest of lines.



SUPER EASY INSTALLATION

With the exclusive Elica Super Easy system, installation can be done in safety in just a few steps. After the hood is locked in place it can be finely adjusted so it is perfectly flush with the ceiling.



COMFORT SILENCE

With the widespread tendency to design kitchens as part of an open-plan living area, it has become increasingly important to be able to rely on hoods with greater power but which are also quieter, so they do not intrude on the surroundings. With Elica's Comfort Silence hoods, the sound level even at maximum extraction speed does not disturb or interfere with normal conversation.



REGENERATABLE FILTER

The traditional charcoal odour filters used when a hood is installed in recirculating mode must be replaced every 3 to 6 months. Elica has designed the innovative Regeneratable odour filter which can be regenerated and lasts up to three years. Just wash it with hot water and neutral soap or in the dishwasher at 65° and dry it in the oven at 100° for 10 minutes every 2 months and it will last for up to 3 years maintaining its original efficiency level of approximately 60%.



HIGH PERFORMANCE REGENERATABLE FILTER

The High Performance Regeneratable Filter has been developed by Elica for maximum performance. This filter guarantees a filtering efficiency of more than 80%, as compared to the market average of 60%. These filters can be regenerated in the same way as standard long life filters and also last for up to 3 years. These high performance filters are the ideal solution if you like cooking dishes which take a long time to cook..



CERAMIC HP FILTER

Elica's latest filter for recirculating versions of NikolaTesla has been designed for the highest performance and the longest life. It's performance is maintained by simply regenerating in an oven and it lasts for up to 5 years making it the most environmentally friendly as well as cost effective filter available.



MULTI-D CAPTURE

Elica's radical new Multi-D capture design greatly increases the speed of the air entering the hood from all sides which significantly improves fume capture of vertical and angled hoods.



DIM LIGHT

The level of illumination can be adjusted at any time to adapt to the time of day or to what's going on in the home. The dimmable LEDs always create the right atmosphere and reduce energy consumption..



TUNE WHITE

The ability to choose the preferred shade of light always creates the right atmosphere. Our range starts from a very warm tone, 2400°K, to experience intimate and convivial moments, up to a cool daylight 5000°K, ideal during the preparation of food. With Tune White, you can also align the colour of the light from the hood with the rest of the lights in the room for uniform lighting.



AIRMATIC

Once the Airmatic function is activated, the product's intelligent sensor system detects the quantity and above all the quality of the fumes produced and sets the most suitable aspiration power.

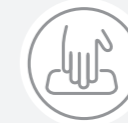

EASY MAINTENANCE

Keeping your hood clean not only ensures good hygiene in the kitchen but also a long life. Elica products are designed with materials and finishes for easy maintenance. All the components, such as the grease and odour filters, can be easily accessed and removed so they can be cleaned and if necessary replaced.



AUTOCAPTURE

When it is important to focus only on cooking operations, you can activate this function. The aspiration system adjusts automatically to the number and power of the cooking zones you are using.



COOKING



MULTI FLEXI SPACE

With the Multi Flex Space design, you have more space available both in length and width when using large pots. You can slide the pans from one burner to another without lifting them.



DUAL BURNER

The Dual Burner, is ideal for small or large pans. The innovative burner features a double crown with independent ignition of each burner, so perfect for both a small coffee pot or a large pan.



BRIDGE ZONE

This function lets you merge 2 adjacent cooking zones, maintaining a uniform, constant temperature, even when using very large pans.



CHILD LOCK

The Child Lock function prevents the hob's cooking zones or extraction being turned on accidentally.



TEMPERATURE MANAGER

Your dishes will always be cooked at the perfect temperature when you use this function that lets you set the hob with 3 programmes (42, 72 or 92 degrees). The temperature settings have been optimised for both very delicate cooking (mousses, sauces, keeping dishes warm) as well as cooking at high power (boiling).



POWER LIMITATION

When you do not have a powerful enough electricity supply available you can set the Power Limitation during installation to limit the maximum power absorbed by your hob.



COOKING



TIMER

Forget about cooking times by turning on the timer. Just set the minutes and start the countdown. At the end, the cooking zone will automatically switch off and a beeper will sound. You can set independent timers on more than one zone at the same time.



KEEP WARM

The Keep Warm function keeps dishes that have just been cooked warm or re-heats a dish that has gone cold. This is useful if you cook at one time but want to eat at a different time. The Keep Warm function can be enabled for any zone.



STOP&GO

If you are interrupted whilst cooking, or you have to go into another room, or you just want a break, with just a single touch of the Stop&Go button you can switch off all the cooking zones and walk away with complete confidence and safety.



PAUSE & RECALL

With Pause & Recall, you can switch off all the cooking areas with one single gesture and then, restart them with a simple press of a button at the same previously set power.



POT DETECTOR

With Pot Detector, the hob automatically detects the presence of the pot on the cooking area and provides heat only when it is correctly positioned.



DUCT SIZE

It is essential that the correct (or larger) size of ducting is used otherwise the performance will be significantly affected and the noise increased. Increasing the length and the number of bends in ducting will significantly reduce the airflow.



MINIMUM HEIGHT - GAS HOB

The minimum height above the top of the pan supports of a gas hob that the hood can be installed. This is subject to the installation instructions produced by the hob manufacturer which should be checked before any design is finalised.



MINIMUM HEIGHT - ELECTRIC HOB

The minimum height above the top of the pan supports of an electric hob that the hood can be installed. This is subject to the installation instructions produced by the hob manufacturer which should be checked before any design is finalised.

NIKOLATESLA



OPERATION AND MAIN ADVANTAGES

Quality of air has always been key to Elica's products. NikolaTesla extractor-hobs incorporate the very best technology to ensure high-performance and the best extraction of fumes and of odours.

HIGHEST EXTRACTION SPEED

All the NikolaTesla models have the highest extraction speed on the market at 5.1 m/s so they can capture all the fumes and odours as they start to rise for the best efficiency and performance available.



MORE SPACE FOR DRAWERS

The product has been designed to optimise the internal space of the cabinet. The adjustable outlet duct which sits flush at the rear of the cabinet makes room for deeper and more spacious drawers to store food or kitchen utensils.



SMART SENSORS AND THAT'S ALL YOU NEED TO KNOW

The innovative Airmatic function involves the use of smart sensors which are able to detect the quantity and quality of the fumes produced and to set the most suitable extraction power accordingly.

SELF-ADJUSTING EXTRACTION

With Autocapture, you can concentrate on your recipe and leave the hob to automatically adjust the extraction speed based on the number and power of the cooking zones being used.

FAST AND EASY TO CLEAN

The smooth, seamless surface of NikolaTesla is one of the innovative features of the new generation of Elica extraction hobs. The seamless ceramic glass is an elegant design detail that also makes short work of cleaning.



PRACTICAL MAINTENANCE

Beauty is combined with practicality when it comes to maintenance as well. The system, patented by Elica, allows the grease filters and the ceramic odour filters used by recirculating models to be removed from above. The large opening with its stylish cover means the spillage compartment can be washed easily and safely.



IMPROVED ODOUR FILTERING CAPABILITY

The recirculating models in the NikolaTesla range feature a ceramic filter with a very high odour purification efficacy of over 82% compared to a market average of 60%. It can be regenerated for up to 3 years simply by putting it in the oven at 200°C for 45 minutes every 2 to 3 months which makes it both environmentally friendly and very cost effective.

INTUITIVE AND USER-FRIENDLY INTERFACE

Elica extractor hobs feature a simple and intuitive interface to allow you to enjoy the pleasure of cooking every day. The touch control panel allows the cooking areas and hood to be controlled separately and, in standby mode, it becomes totally invisible. Controlling cooking has never been so easy and convenient.

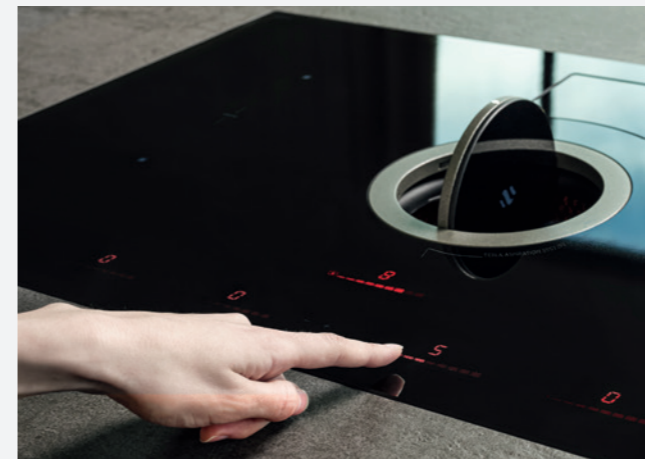



NIKOLATESLA SWITCH

DESIGN FABRIZIO CRISA

83 x 51 x 21 cm
Duct-out / Re-circulating
Black glass, white glass

An elegant disk in black or white glass conceals the heart of the extraction unit - activate with a simple touch. The Direct Slider interface allows the various cooking and extraction areas to be controlled simply and intuitively.

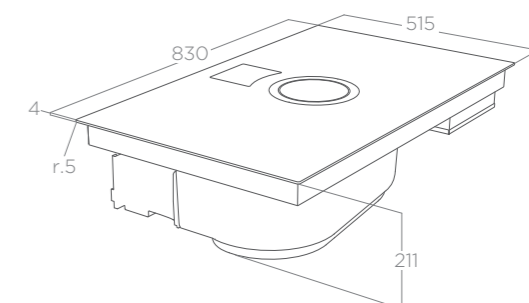
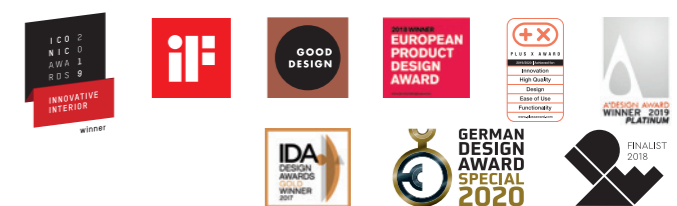

	ASPIRATION SYSTEM	
Model	Duct-out	Re-circulating
Controls	Individual touch control	Individual touch control
Speeds	8 speeds + 2 boost levels	8 speeds + 2 boost levels
Booster airflow	620 m³/h	536 m³/h
Suction speed	5,1 m/s	5,1 m/s
Noise level	60 dBA	64 dBA
Total power absorption	160 W	160 W
Duct size	150 mm	150 mm
Energy class	A+	
Aluminium grease filter	Included	Included
Ceramic filter	*	Included

	INDUCTION HOB
Absorption	7,4 kW
Frequency	50 Hz
Voltage	220 - 240 V
Zone number	4 (2,1 - 3 kW) - 210x190 mm
Bridge zone	2



	OPTIONAL ACCESSORIES
Replacement Ceramic filter	KIT0120952

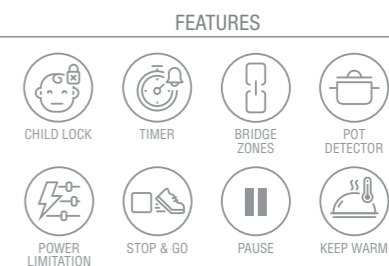

	MODELS
NIKOLATESLA SWITCH Black Re-circulating	PRF0146210A
NIKOLATESLA SWITCH Black Duct-out	PRF0146212A
NIKOLATESLA SWITCH White Re-circulating	PRF0146213A
NIKOLATESLA SWITCH White Duct-out	PRF0146216A

* Not used for Duct-out hoods



NIKOLATESLA ONE

DESIGN FABRIZIO CRISÀ

83 x 51 x 21 cm
Duct-out / Re-circulating
Black glass, white glass

The product, winner of the 25th ADI Compasso d'Oro award, combines cutting-edge downdraft technology with Elica's signature state-of-the-art design. The Direct Slider interface allows the various cooking and extraction areas to be controlled simply and intuitively.

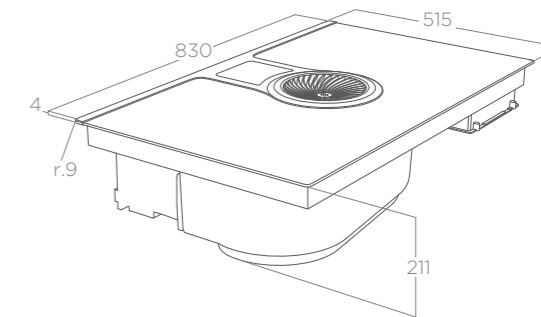

NIKOLATESLA ONE



NIKOLATESLA ONE HP



	ASPIRATION SYSTEM	
Model	Duct-out	Re-circulating
Controls ONE HP	Individual touch control	Individual touch control
Controls ONE	Circular touch control	Circular touch control
Speeds	9 speeds + boost	9 speeds + boost
Booster airflow	647 m ³ /h	536 m ³ /h
Suction speed	5,1 m/s	5,1 m/s
Noise level	59 dBA	65 dBA
Total power absorption	160 W	160 W
Duct size	150 mm	150 mm
Energy class	A+	
Aluminium grease filter	Included	Included
Ceramic filter	*	Included

	INDUCTION HOB
Absorption	7,4 kW
Frequency	50 - 60 Hz
Voltage	220 - 240 V
Zone number ONE HP	4 (2,1-3,7 kW) - 180x200 mm
Zone number ONE	1 (2,1 - 3 kW) - 180x200 mm 1 (1,6 - 1,85 kW) - 180x200 mm 1 (2,3 - 3 kW) - Ø 200 mm 1 (1,4 kW) - Ø 160 mm
Bridge zone	2 (ONE HP) - 1 (ONE)

- CERAMIC HP FILTER
- COMFORT SILENCE
- EASY TO MAINTAIN
- AUTO CAPTURE
- 222x89 mm

- FEATURES
- | ONE HP | ONE |
|---------------------|---------------------|
| CHILD LOCK | CHILD LOCK |
| TIMER | TIMER |
| BRIDGE ZONES | BRIDGE ZONES |
| POT DETECTOR | POT DETECTOR |
| POWER LIMITATION | POWER LIMITATION |
| STOP & GO | POWER LIMITATION |
| PAUSE | TEMPERATURE MANAGER |
| TEMPERATURE MANAGER | POT DETECTOR |
| KEEP WARM | KEEP WARM |

	OPTIONAL ACCESSORIES
Replacement Ceramic filter	KIT0120952

	MODELS
NIKOLATESLA HP Black Duct-out	PRF0120975
NIKOLATESLA HP Black Re-circulating	PRF0120976
NIKOLATESLA Black Duct-out	PRF0120977
NIKOLATESLA Black Re-circulating	PRF0120978

* Not used for Duct-out hoods



NIKOLATESLA LIBRA

DESIGN FABRIZIO CRISÀ

THE FIRST HOB WITH INTEGRATED SCALES

With NikolaTesla libra, following the steps of each recipe has never been simpler and faster thanks to the integrated scales, always within easy reach.

Products can be weighed directly in the pan, at any temperature at any time while cooking.

FUNCTIONS

- ✓ **WEIGHT RESET**
the pan and its contents can be weighed by progressively resetting the value in order to add other ingredients and know the final overall weight
- ✓ **TARE FUNCTION**
allows multiple ingredients to be weighed one at a time, starting from zero each time
- ✓ **HOLD FUNCTION**
stores the selected weight
- ✓ **SELECT UNIT OF MEASURE**



The NikolaTesla Libra interface is extremely intuitive to use thanks to a single direct slider, which controls both cooking and extraction functions.

The scale has a dedicated user interface, allowing it to be used even with the product completely turned off. Simply rest the pot on top to activate the weighing function.





NIKOLATESLA LIBRA

DESIGN FABRIZIO CRISA



83 x 51 x 21 cm
 Duct-out / Re-circulating
 Black glass+ cast iron, White glass + cast iron
 The only extractor hob with built-in scales.

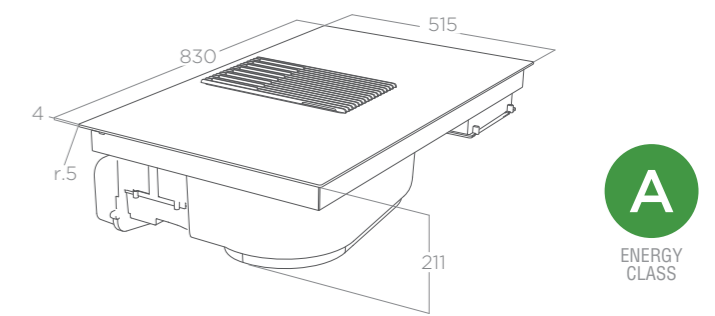

	ASPIRATION SYSTEM	
Model	Duct-out	Re-circulating
Controls	Touch control	Touch control
Speeds	3 speeds + 2 boost levels	3 speeds + 2 boost levels
Booster airflow	610 m³/h	422 m³/h
Noise level	61 dBA	71 dBA
Suction speed	5,1 m/s	5,1 m/s
Total power absorption	310 W	310 W
Duct size	150 mm	150 mm
Energy class	A	A
Aluminium grease filter	Included	Included
Charcoal fibre filter	*	Included

	INDUCTION HOB
Absorption	7,4 kW
Frequency	50 Hz
Voltage	220 - 240 V
Zone number	2 (1,6 - 1,85 kW) - 210x190 mm 2 (2,1 - 3 kW) - 210x190 mm
Bridge zone	2

- FEATURES
- CHILD LOCK
 - TIMER
 - BRIDGE ZONES
 - POT DETECTOR
 - POWER LIMITATION
 - STOP & GO
 - KEEP WARM

- CERAMIC HP FILTER
- EASY TO MAINTAIN
- AUTO CAPTURE
- 222x89 mm

OPTIONAL ACCESSORIES

Replacement charcoal fibre filter	KIT0147855
Optional ceramic filter	KIT0120952

MODELS

NIKOLATESLA LIBRA Black Duct-out	PRF0147744
NIKOLATESLA LIBRA Black Re-circulating	PRF0147745
NIKOLATESLA LIBRA White Duct-out	PRF0147774
NIKOLATESLA LIBRA White Re-circulating	PRF0147775

* Not used for Duct-out hoods

NIKOLATESLA
PRIME PLUS

DESIGN FABRIZIO CRISÀ





NIKOLATESLA PRIME - PRIME PLUS

DESIGN FABRIZIO CRISÀ



83 x 51 x 21 cm
Duct-out / Re-circulating
Black glass+ cast iron

An unrivalled combination of performance elegant design and great value.

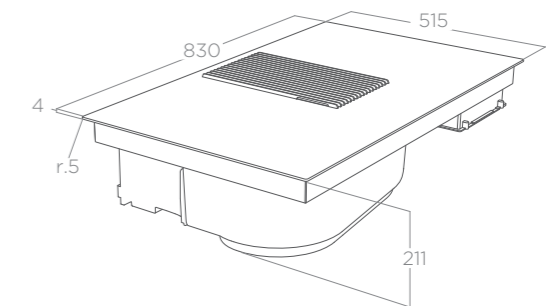

	ASPIRATION SYSTEM	
Model	Duct-out	Re-circulating
Controls	Touch control	Touch control
Speeds	3 speeds + 2 boost levels	3 speeds + 2 boost levels
Booster airflow	610 m³/h	422 m³/h
Suction speed	5,1 m/s	5,1 m/s
Noise level	61 dBA	71 dBA
Total power absorption	310 W	310 W
Duct size	150 mm	150 mm
Energy class	A	
Aluminium grease filter	Included	Included
Charcoal fibre filter	*	Included

	INDUCTION HOB
Absorption	7,4 kW
Frequency	50 Hz
Voltage	220 - 240 V
Zone number	2 (1,2 - 1,4 kW) - Ø 160 mm 2 (2,3 - 3 kW) - Ø 200 mm
Bridge zone	1 (Prime Plus)

FEATURES

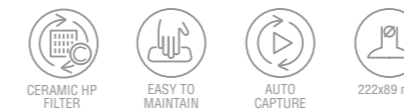

OPTIONAL ACCESSORIES

Replacement charcoal fibre filter	KIT0147855
Optional ceramic filter	KIT0120952

MODELS

NIKOLATESLA PRIME Black Duct-out	PRF0138475A
NIKOLATESLA PRIME Black Re-circulating	PRF0143159A
NIKOLATESLA PRIME PLUS Duct-out	PRF0155873A
NIKOLATESLA PRIME PLUS Re-circulating	PRF0155874A

* Not used for Duct-out hoods



LIVING ON WATER
Brand van Eylandt — Lighting Sculptures
ENTREWAYS OF MILAN — INGREDIENTI DI MILANO

NIKOLATESLA FLAME
DESIGN FABRIZIO CRISÀ



NIKOLATESLA FLAME

DESIGN FABRIZIO CRISA



88 x 51 x 21 cm
 Duct-out / Re-circulating
 Black glass + cast iron, grey glass + cast iron

The first gas extraction hob. The cast iron pan supports combine aesthetic appeal and functionality with the utmost safety. There is even a wok support available as an accessory.

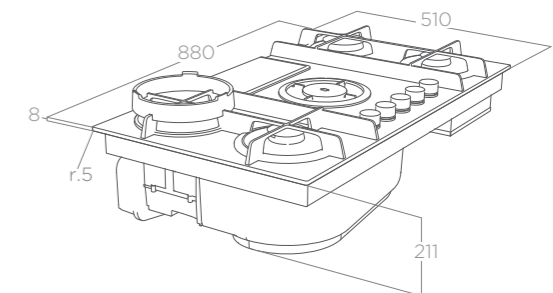

	ASPIRATION SYSTEM	
Model	Duct-out	Re-circulating
Controls	Rotative	Rotative
Speeds	3 speeds + 2 boost levels	3 speeds + 2 boost levels
Booster airflow	610 m³/h	422 m³/h
Suction speed	5,1 m/s	5,1 m/s
Noise level	61 dBA	71 dBA
Total power absorption	310 W	310 W
Duct size	150 mm	150 mm
Energy class	A	
Aluminium grease filter	Included	Included
Charcoal filter	*	Included

	GAS HOB
Absorption	10 W
Frequency	50 Hz
Voltage	220 - 240 V
zone number	4 + 1

	BURNER TYPE
1st element	Dual special (3,5kW)
2nd element	Semi rapid (1,75 kW)
3rd element	Semi rapid (1,75 kW)
4th element	Rapid (3,0 kW)

	FEATURES
	CERAMIC HP FILTER
	EASY TO MAINTAIN
	222x89 mm
	DUAL BURNER
	MULTI FLEXI SPACE

	OPTIONAL ACCESSORIES
Replacement charcoal filter	KIT0147855
Optional ceramic filter	KIT0120952
Wok Burner Support	KIT0160040

	MODELS
NIKOLATESLA FLAME Black Re-circulating	PRF0147741A
NIKOLATESLA FLAME Black Duct-out	PRF0147740A
NIKOLATESLA FLAME Grey Re-circulating	PRF0147743A
NIKOLATESLA FLAME Grey Duct-out	PRF0147742A

* Not used for Duct-out hoods

Nikola Tesla has been designed with the greatest flexibility to suit a huge variety of kitchens. The recirculating version comes complete with every component usually needed for installation including the unique chrome outlet grill for the plinth. For the duct out version a wide range of ducting is available to suit all installation requirements.

Nikola Tesla can be installed on the counter top or flush fitted with the counter top.

NIKOLATESLA LIBRA / ONE / PRIME / SWITCH

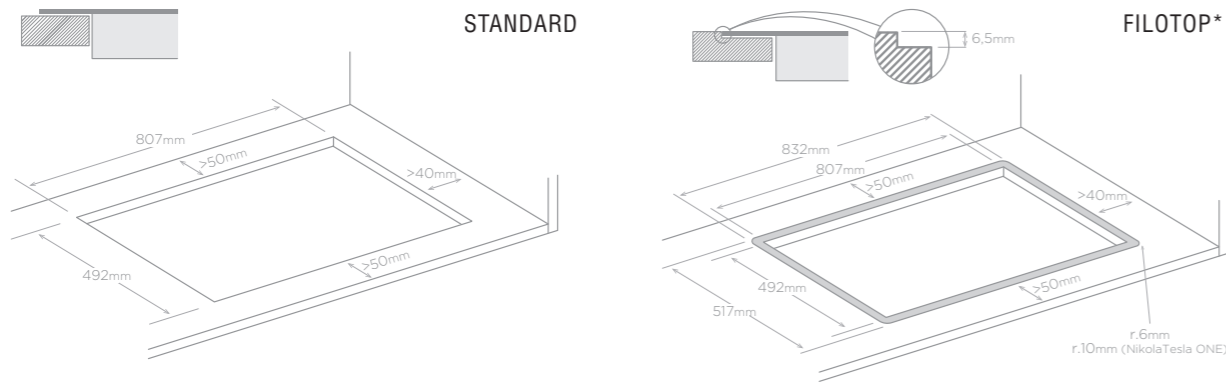

NIKOLATESLA FLAME

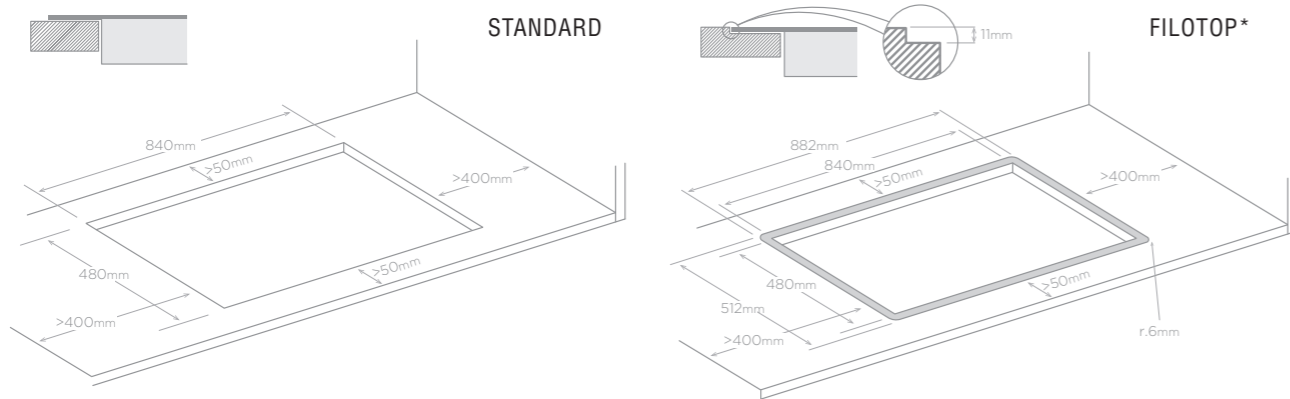

* Recommended filotop dimensions: for different tolerances, respect the actual dimensions of the glass. FOR FURTHER INFORMATION, CONSULT THE PRODUCT INSTALLATION MANUAL.

By opening the cover, you can remove the high performance ceramic filters (Regeneratable) and empty the split liquid collector that protects the motor in the case of even large spillages.

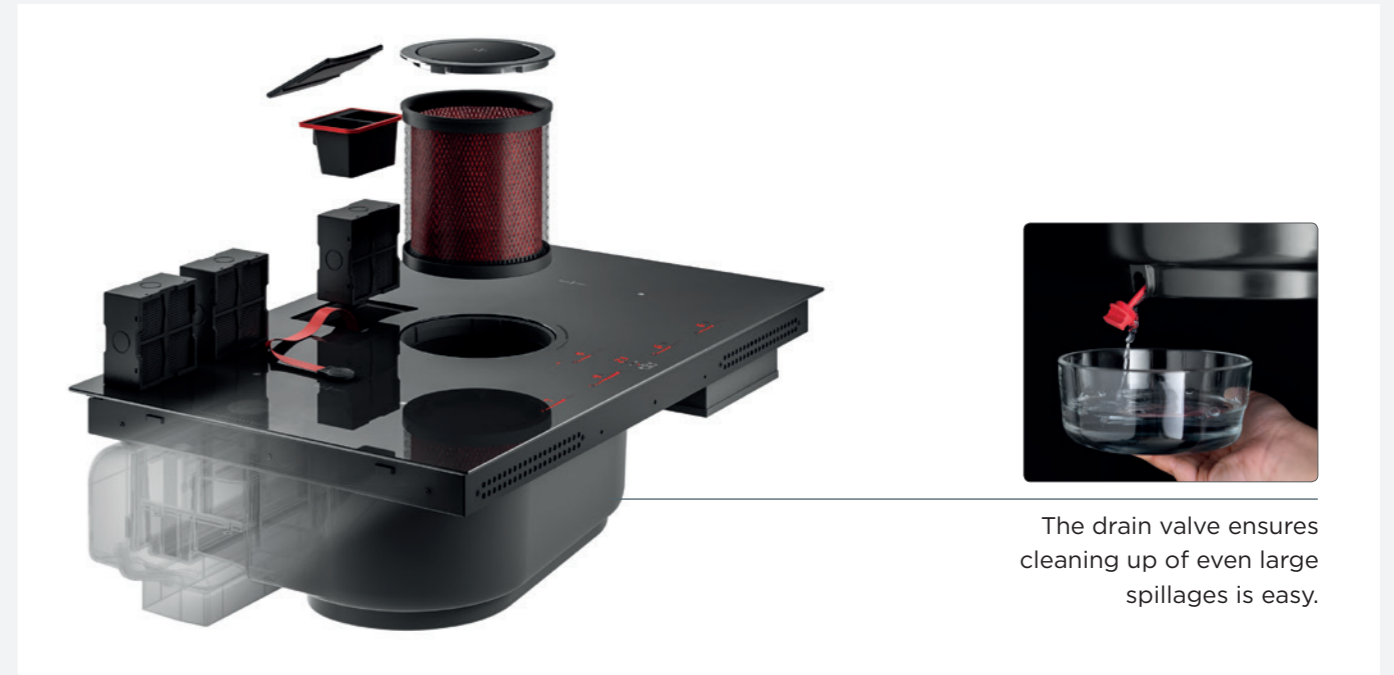

The drain valve ensures cleaning up of even large spillages is easy.

Thanks to the wide range of ducting available your NikolaTesla can be installed in the way that best suits your needs.

NIKOLATESLA STANDARD RE-CIRCULATING MODELS *



NIKOLATESLA STANDARD DUCT-OUT MODEL *



* All images are samples installation

NIKOLATESLA FIT

DESIGN FABRIZIO CRISÀ





NIKOLATESLA FIT

DESIGN FABRIZIO CRISÀ

60x51,5x25,2 cm 72x51,5x25,2 cm
56x49 cm (cut)
Duct-out
Black glass

All the performance of an Elica NikolaTesla hob in 60cm and 72cm spaces.

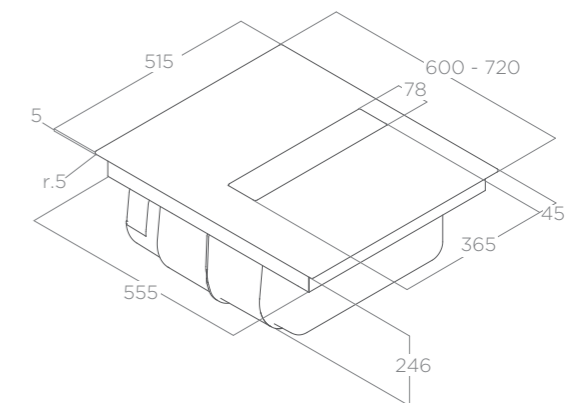

NIKOLATESLA FIT 70



NIKOLATESLA FIT 60



ASPIRATION SYSTEM	
Controls	Touch control 3 speeds + 2 boost levels
Booster airflow	620 m ³ /h
Suction speed	5,1 m/s
Noise level	59 dBA
Total power absorption	145 W
Duct size	150 mm
Energy class	A
Aluminium grease filter	Included

INDUCTION HOB	
Absorption	7,2 kW
Frequency	50 Hz
Power limitation	3,1 - 4,5 kW
Voltage	220 - 240 V
Cooking zones (Size-Power)	1 200x180 mm - 2,1/3,0 kW 2 200x180 mm - 1,6/1,85 kW 3 Ø200 mm - 2,3/3,0 kW 4 Ø160 mm - 1,2/1,4 kW
Bridge zone	1



OPTIONAL ACCESSORIES	
Re-circulating kit	KIT0167757
Replacement ceramic filter	KIT0120952

MODELS	
NIKOLATESLA FIT Black A 60	PRF0167053
NIKOLATESLA FIT Black A 70	PRF0167054

EXCELLENCE IN SMALL SPACES

Small spaces are becoming more and more widespread in homes now which is why multi-functional products, capable of optimising space, are excellent solutions.

Designed to meet the exacting needs of those unwilling to renounce excellence even in small spaces, NikolaTesla Fit is the first induction hob with integrated extraction that can also be installed in 60-cm wide base units with an overall width area of 60 or 72 cm.



ELEGANT AND FUNCTIONAL DESIGN

Rotate the central panel to activate the extraction in a perfect combination of style, comfort and functionality. The compact dimensions and shape have been designed to leave space in the cabinet and total freedom of movement on the hob with pans of any kind. The heart of this efficient and silent extraction unit is totally concealed by the glass top which covers the product discretely and elegantly.



SIMPLE CLEANING AND MAINTENANCE

NikolaTesla Fit is designed to be really easy to clean and maintain. The fully linear ceramic glass surface makes cleaning very quick and easy. The central aesthetic element can be removed and washed. It is also the access point for extracting the filters and carrying out maintenance. The inner compartment can be accessed in complete safety and any excess liquid can be removed thanks to a special drain valve.

FULL INSTALLATION FLEXIBILITY

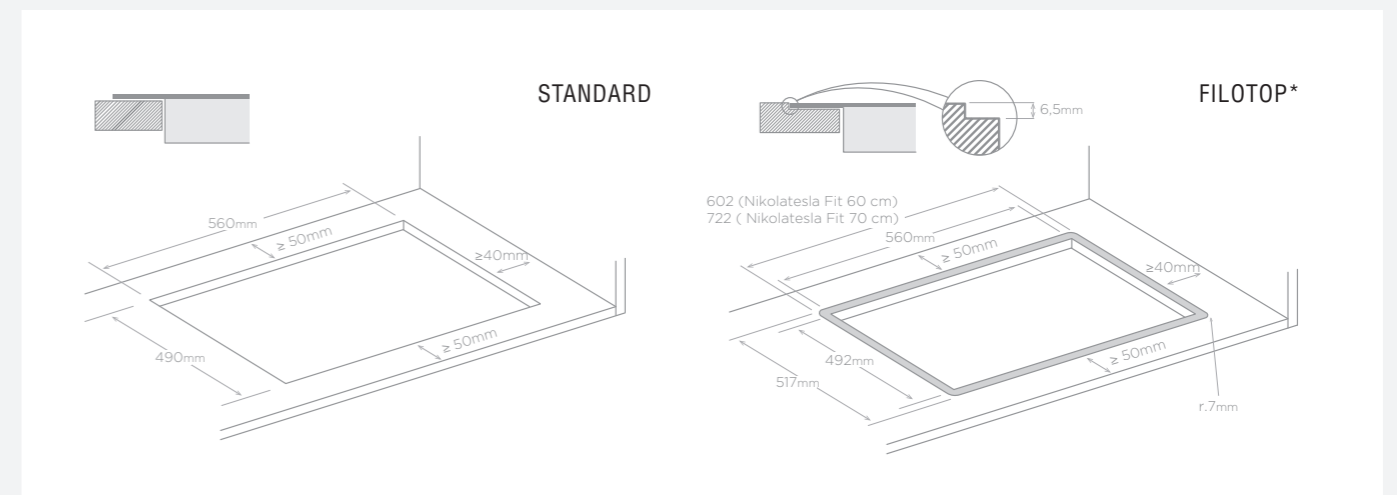
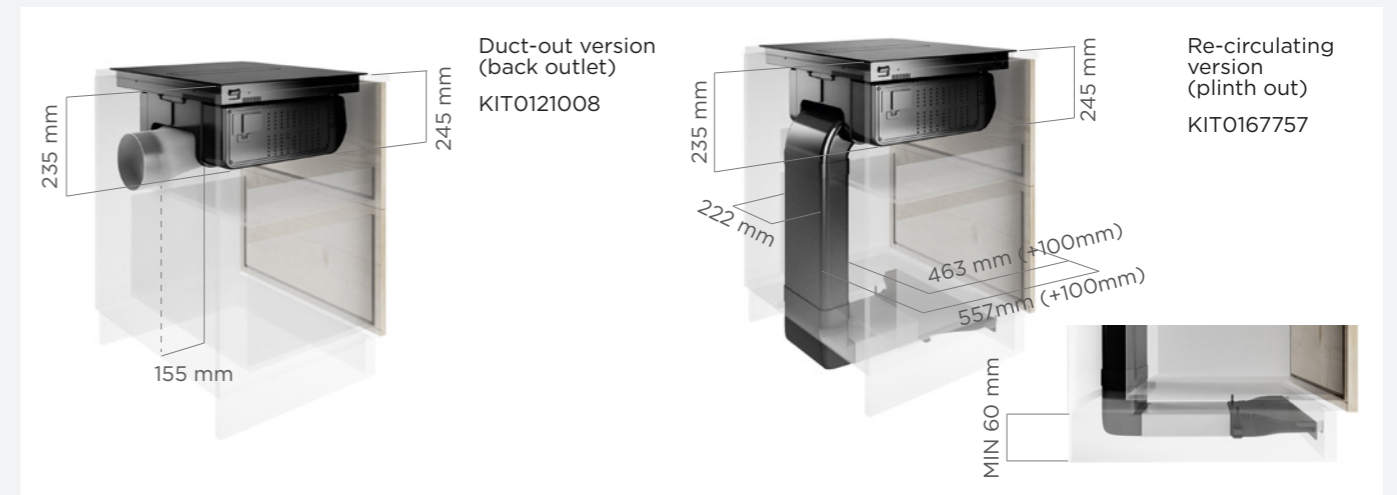

* Recommended filotop dimensions: for different tolerances, respect the actual dimensions of the glass. FOR FURTHER INFORMATION, CONSULT THE PRODUCT INSTALLATION MANUAL.

ACCESSORY PIPE FITTINGS FOR DUCT-OUT VERSION



222x89x1000 mm
KIT0120991

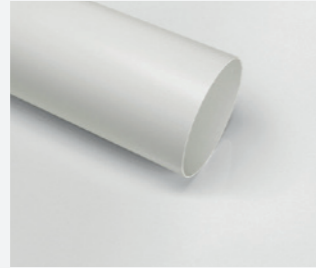

Ø150x500 mm
KIT0120996

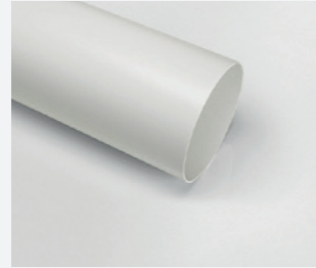

Ø150x1000mm
KIT0121000



227x94x80mm
KIT0121001



15° 227x138x94
KIT0121002



Ø158x59mm
KIT0121003

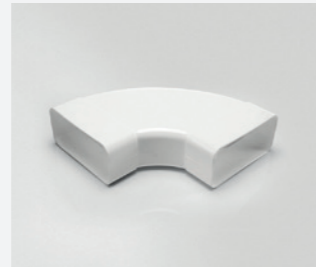

90° 227x288x94mm
KIT0121004



90° 227x94mm
KIT0121005



90° - Ø157
KIT0121006



227x94 - Ø146mm
KIT0121007

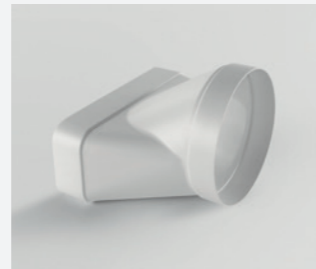

227x94 - Ø153mm
KIT0121008

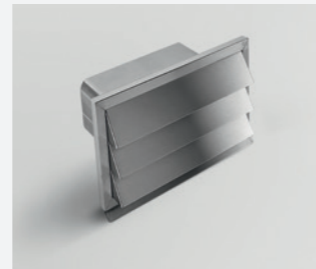

int 216x82 / est 290x160 mm
KIT0121009

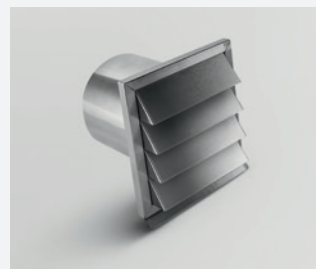

190x190 - Ø147mm
KIT0121010



227x94 mm
KIT0126810

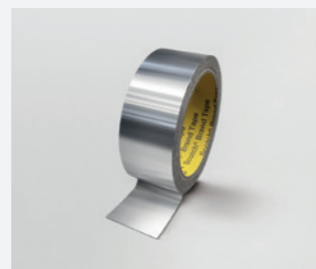

50 mm x 25 m
KIT0161453

ACCESSORY PIPE FITTINGS FOR RE-CIRCULATING VERSION



218x55x500 mm
KIT0121012



218x55x1000 mm
KIT0121013

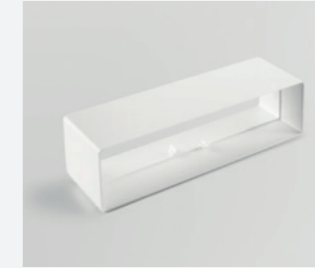

218x55x70 mm
KIT0121015



90° 218x55 mm
KIT0121016



218x55 mm
KIT0121017

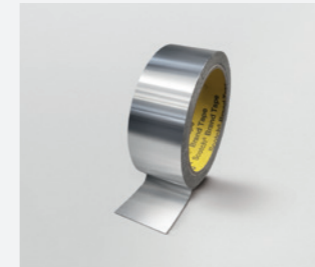

50 mm x 25 m
KIT0161453



Deflector under plinth
KIT0168750

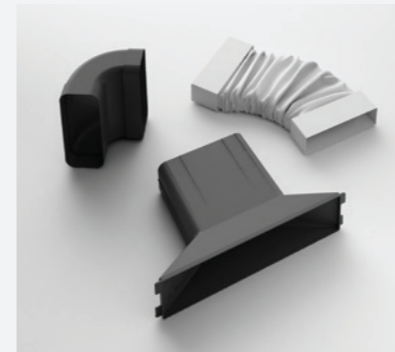

KIT0140820
NikolaTesla filter kit for base depth > 70 cm

Available for
NIKOLATESLA SWITCH
NIKOLATESLA ONE
NIKOLATESLA PRIME
NIKOLATESLA FLAME
NIKOLATESLA LIBRA



KIT0167757
Re-circulating kit plinth-out

Available for
NIKOLATESLA FIT

WALL





SUPER PLAT

DESIGN FABRIZIO CRISA

80 cm
Duct-out / Re-circulating
Black glass + cast iron effect, grey glass + cast iron effect

Ultra slim and highly effective. As well as conventional touch controls SUPER PLAT can be controlled by the Elica App or by voice assistant. In line with latest kitchen trends Elica has developed new combinations of finishes for the ultimate urban chic.

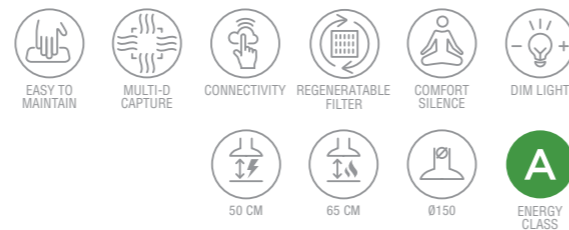

LIGHTING	
Type	Strip LED 1x7 W
Intensity	197 lux
Temperature	3500 K

SPECIFICATION	
Controls	Capacitive touch control
Speeds	3 speeds + 2 boost levels
Booster airflow	740 m³/h
Noise level	57 dBA
Total absorption	277 W
Duct size	150
Energy class	A
Aluminium grease filter	Included
Regeneratable filter	Included

OPTIONAL ACCESSORIES	
Black chimney kit	KIT0166364
Stainless steel chimney kit	KIT0171543

MODELS	
SUPER PLAT 80 Black	PRF0164980
SUPER PLAT 80 Grey	PRF0165017

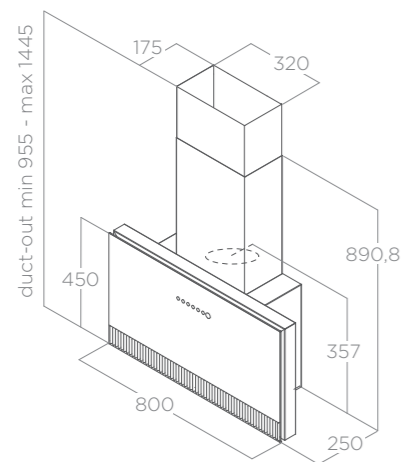

PLAT

DESIGN FABRIZIO CRISA

55 - 80 cm
Duct-out / Re-circulating
Black glass, white glass



LIGHTING	
Type	Strip LED 1x7 W
Intensity	365 lux
Temperature	3500 K

SPECIFICATION	
Controls	Capacitive touch control
Speeds	3 speeds + boost
Booster airflow	710 m³/h
Noise level	57 dBA
Total absorption	277 W
Duct size	150
Energy class	A
Aluminium grease filter	Included
Regeneratable filter	Included

OPTIONAL ACCESSORIES	
Black chimney kit	KIT0166364
Stainless steel chimney kit	KIT0171543

MODELS	
PLAT 55 Black	PRF0164946
PLAT 80 Black	PRF0164874
PLAT 55 White	PRF0165707
PLAT 80 White	PRF0165712

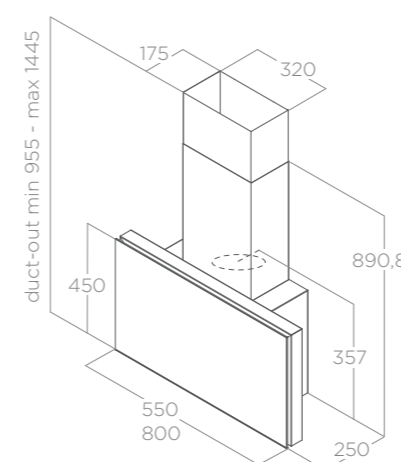



RULES DEKTON

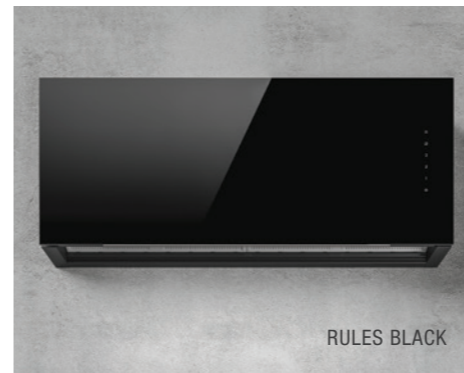

RULES BLACK



RULES CUSTOMISABLE

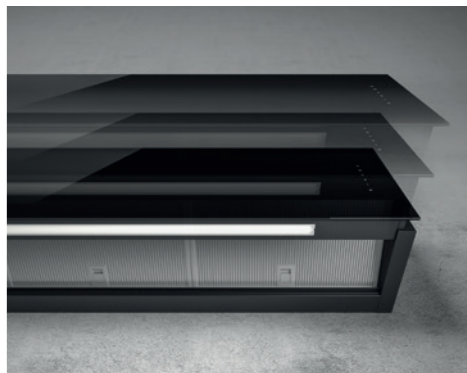

RULES

DESIGN FABRIZIO CRISA



60 - 90 - 120 cm
 Duct-out / Re-circulating
 Black glass, stonewear Dekton, customisable

The CUSTOMISABLE version of Rules is a unique model that can be personalised to suit customer needs. It can be finished with the same material used for your kitchen. The images shown are only an example of the possible solutions.

- SPECIAL MATERIAL
- EASY TO MAINTAIN
- TOTAL INTEGRATION
- REGENERATABLE FILTER
- COMFORT SILENCE
- 50 CM (Black) & 45 CM (Dekton & customisable)
- 65 CM
- Ø150
- ENERGY CLASS A

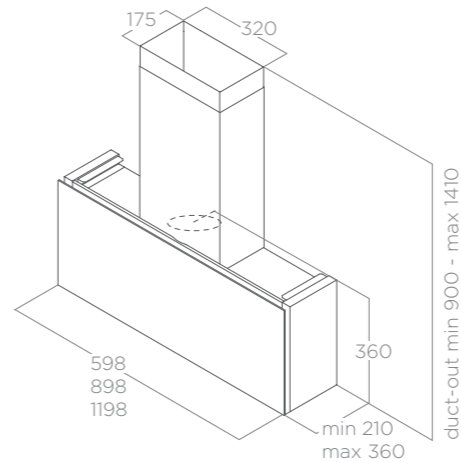

LIGHTING

Type	Strip LED 2x7 W (Dekton - Customisable) Strip LED 1x7 W (Black)
Intensity	365 (Black) - 310 (Dekton-Customisable) lux
Temperature	3500 K

SPECIFICATION

	Black	Dekton / Customisable
Controls	Capacitive touch control	Electronic push button
Speeds	3 speeds + boost	3 speeds + boost
Booster airflow	700 m ³ /h	700 m ³ /h
Noise level	58 dBA	58 dBA
Total absorption	277 W	277 W
Duct size	150	
Energy class	A	
Aluminium grease filter	Included	
Regeneratable filter	Included	

OPTIONAL ACCESSORIES

Black chimney kit	KIT0166364
Stainless steel chimney kit	KIT0171543

MODELS

RULES 60 Black	PRF0163752
RULES 90 Black	PRF0163751
RULES 120 Black	PRF0163753
RULES 60 Dekton	PRF0163755
RULES 90 Dekton	PRF0163754
RULES 120 Dekton	PRF0163756
RULES 60 Customisable	PRF0163758
RULES 90 Customisable	PRF0163757
RULES 120 Customisable	PRF0163759

BLOOM-S

DESIGN FABRIZIO CRISÀ





BLOOM-S

DESIGN FABRIZIO CRISÀ

85 cm
Duct-out / Re-circulating
White glass, stonewear Dekton

Combining elegance and performance.
Open the flap for increased fume capture during cooking -
close when you have finished.

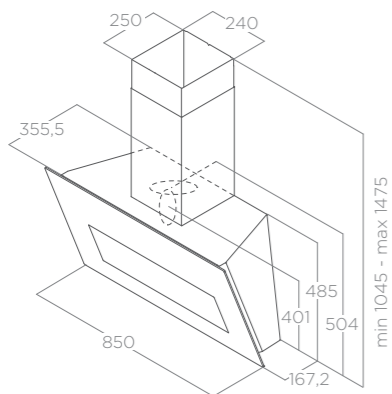
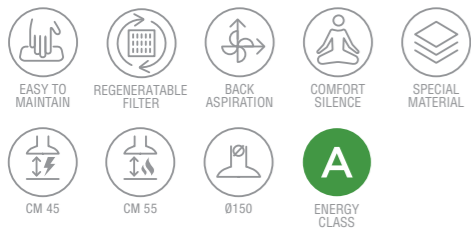

LIGHTING

Type	Strip LED 1x7 W
Intensity	365 lux
Temperature	3500 K

SPECIFICATION

Controls	Infrared touch control
Speeds	3 speeds + 2 boost levels
Booster airflow	750 m³/h
Noise level	53 dBA
Total absorption	277 W
Duct size	150
Energy class	A
Aluminium grease filter	Included
Chimney kit	Included

OPTIONAL ACCESSORIES

Charcoal filter	CFC0140343
Regeneratable filter	CFC0162221

MODELS

BLOOM-S 85 White A	PRF0164490
BLOOM-S 85 Dekton A	PRF0164475

BLOOM

DESIGN FABRIZIO CRISÀ

85 cm
Duct-out / Re-circulating
White glass, grey glass

Combining elegance and performance.
Open the flap for increased fume capture during cooking -
close when you have finished.

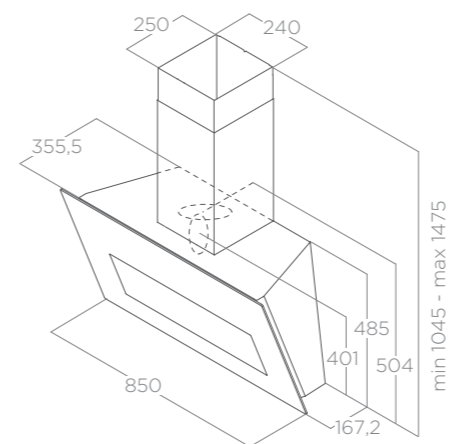
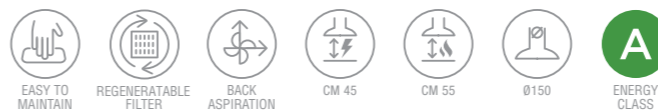

LIGHTING

Type	Strip LED 1x7 W
Intensity	365 lux
Temperature	3500 K

SPECIFICATION

Controls	Capacitive touch control
Speeds	3 speeds + boost
Booster airflow	750 m³/h
Noise level	56 dBA
Total absorption	277 W
Duct size	150
Energy class	A
Aluminium grease filter	Included
Chimney kit	Included

OPTIONAL ACCESSORIES

Charcoal filter	CFC0140343
Regeneratable filter	CFC0162221

MODELS

BLOOM 85 Black A	PRF0164459
BLOOM 85 Grey A	PRF0164462



NUANCE

DESIGN FABRIZIO CRISÀ



75 cm
Duct-out / Re-circulating
Stainless steel to be paneled with drywall (not included),
stainless steel + paintable white

These unique models can be customised to suit the kitchen design. Two versions are available; drywall which takes 6mm dry wall plasterboard (not included) and can be decorated exactly as the kitchen walls, and paintable steel.

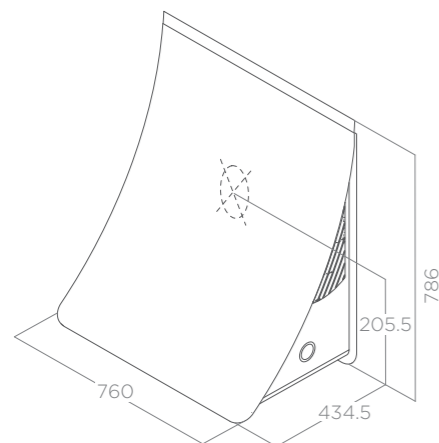

LIGHTING

Type	Strip LED 1x7 W
Intensity	141 lux
Temperature	4000 K

SPECIFICATION

Controls	Electronic rotary
Speeds	3 speeds + boost
Booster airflow	580 m ³ /h
Noise level	62 dBA
Total power absorption	227 W
Duct size	150 mm
Energy class	A
Aluminium grease filter	Included
Charcoal filter	Included

OPTIONAL ACCESSORIES

Regeneratable filter	CFC0162221
----------------------	------------

MODELS

NUANCE Drywall	PRF0096484
NUANCE Paint	PRF0098374

MAJESTIC NO DRIP

DESIGN FABRIZIO CRISÀ

60 - 90 cm
Duct-out / Re-circulating
Black glass + stainless steel

NO DRIP – Condensation can be a problem in kitchens with induction hobs. As these hobs only heat the pans there is no rising warmth to warm the glass of any cooker hoods so condensation can form. With the NO DRIP function the glass panel is warmed (just as in a car's rear windscreen) preventing condensation and any condensation on the internal components is collected in a removeable drip tray.

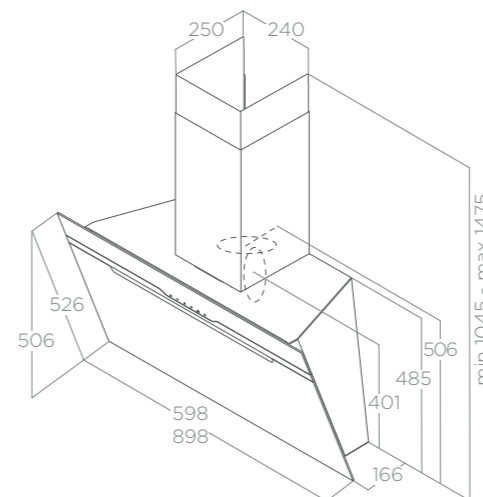

LIGHTING

Type	Strip LED 1x7 W
Intensity	141 lux
Temperature	3500 K

SPECIFICATION

Controls	Capacitive touch control
Speeds	3 speeds + boost
Booster airflow	600 m ³ /h
Noise level	60 dBA
Total power absorption	207 W
Duct size	150 mm
Energy class	A
Aluminium grease filter	Included
Chimney kit	Included

OPTIONAL ACCESSORIES

Charcoal filter	CFC0140343
Regeneratable filter	CFC0162221

MODELS

MAJESTIC NO DRIP 60 Black	PRF0147731
MAJESTIC NO DRIP 90 Black	PRF0147732



IO AIR BLACK



IO AIR VINTAGE

IO AIR WHITE

IO AIR BEAUTY

IO AIR POP

IO AIR NATURE

IO AIR

DESIGN FABRIZIO CRISÀ

75 cm
Duct-out / Re-circulating
White glass, black glass, coloured glass

Upon activation, the center ring electronically moves inwards, allowing perimeter suction.

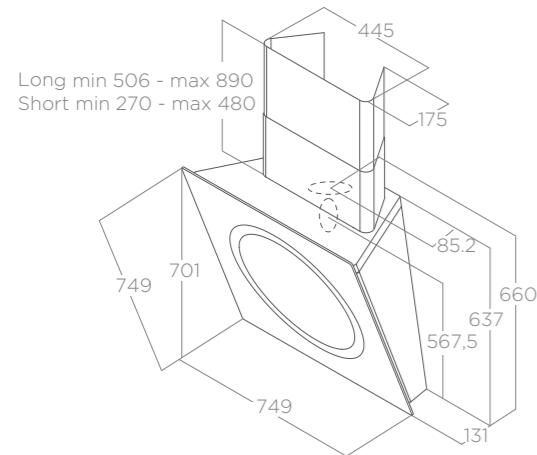

LIGHTING

Type	Strip LED 1x7 W
Intensity	113 lux
Temperature	4000 K

SPECIFICATION

Controls	Capacitive touch control
Speeds	3 speeds + boost
Booster airflow	650 m ³ /h
Noise level	60 dBA
Total power absorption	247 W
Duct size	150 mm
Energy class	A
Aluminium grease filter	Included
Charcoal filter	Included

OPTIONAL ACCESSORIES

Short chimney kit	KIT0010700
Long chimney kit	KIT0010439
Regeneratable filter	CFC0162221

MODELS

IO AIR White	PRF0094734
IO AIR Black	PRF0094744
IO AIR Pop	PRF0098373
IO AIR Beauty	PRF0100137
IO AIR Vintage	PRF0100138
IO AIR Nature	PRF0100231



MINI IO

ELICA DESIGN CENTER

55 cm
Duct-out / Re-circulating
White glass, black glass

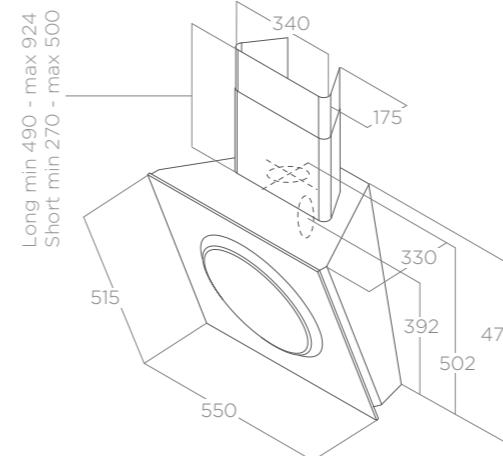

LIGHTING

Type	LED 2x2,5 W
Intensity	341 lux
Temperature	4000 K

SPECIFICATION

Controls	Soft Light push button
Speeds	3 speeds
Max airflow	590 m ³ /h
Noise level	63 dBA
Total power absorption	225 W
Duct size	150 mm
Energy class	A
Aluminium grease filter	Included
Regeneratable filter	Included

OPTIONAL ACCESSORIES

Short chimney kit	KIT01797
Long chimney kit	KIT01513

MODELS

MINI IO Black	61614583A
MINI IO White	61614584A



FILM

DESIGN FABRIZIO CRISÀ

80 cm
Duct-out / Re-circulating
White glass, black glass

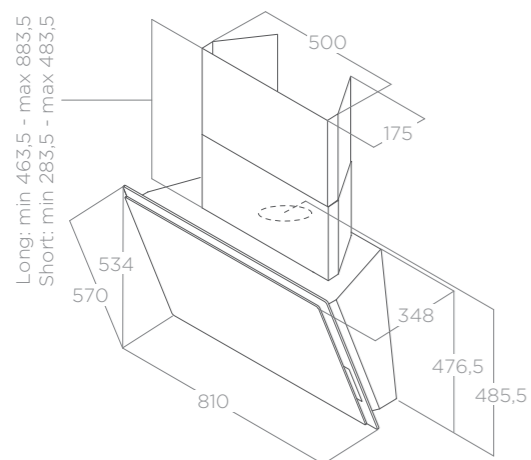

LIGHTING

Type	Strip LED 1x7 W
Intensity	147 lux
Temperature	4000 K

SPECIFICATION

Controls	Infrared touch control
Speeds	3 speeds + boost
Booster airflow	670 m³/h
Noise level	62 dBA
Total power absorption	247 W
Duct size	150 mm
Energy class	A
Aluminium grease filter	Included
Charcoal filter	Included

OPTIONAL ACCESSORIES

Regeneratable filter	CFC0162221
Short chimney kit	KIT0010704
Long chimney kit	KIT0010703

MODELS

FILM Black	PRF0094251
FILM White	PRF0097706

LEAF

DESIGN FABRIZIO CRISÀ

80 cm
Duct-out / Re-circulating
White glass, black glass

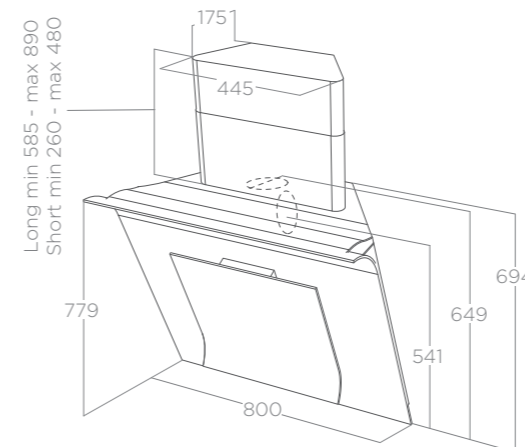

LIGHTING

Type	Neon 2x14 W
Intensity	59 lux
Temperature	4000 K

SPECIFICATION

Controls	Capacitive touch control
Speeds	3 speeds + boost
Booster airflow	760 m³/h
Noise level	70 dBA
Total power absorption	328 W
Duct size	150 mm
Energy class	B
Aluminium grease filter	Included
Charcoal filter	Included
Regeneratable filter	Included

OPTIONAL ACCESSORIES

Short chimney kit	KIT0010700
Long chimney kit	KIT0010439

MODELS

LEAF Black	PRF0010417B
LEAF White	PRF0010418B



APLOMB

DESIGN FABRIZIO CRISA

60 - 90 cm
Duct-out / Re-circulating
Black glass, white glass

The CUSTOMISABLE version of Rules is a unique model that can be personalised to suit customer needs. It can be finished with the same material used for your kitchen. The images shown are only an example of the possible solutions.

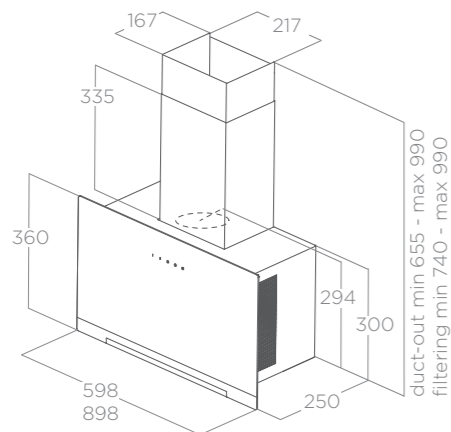
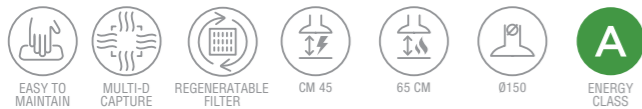

LIGHTING	
Type	Strip LED 1x3 W
Intensity	84 lux
Temperature	3500 K
SPECIFICATION	
Controls	Capacitive touch control
Speeds	3 speeds + boost
Booster airflow	680 m ³ /h
Noise level	64 dBA
Total absorption	233 W
Duct size	150
Energy class	A
Aluminium grease filter	Included
Chimney kit	Included

OPTIONAL ACCESSORIES	
Charcoal filter	CFC0140343
Recirculating kit 1st installation	KIT0160286
Regeneratable filter	CFC0162221

MODELS	
APLOMB 60 Black	PRF0166938
APLOMB 90 Black	PRF0166939
APLOMB 60 White	PRF0166940
APLOMB 90 White	PRF0166941



SHEEN-S

DESIGN FABRIZIO CRISA

60 - 90 cm
Duct-out / Re-circulating
Black glass, white glass

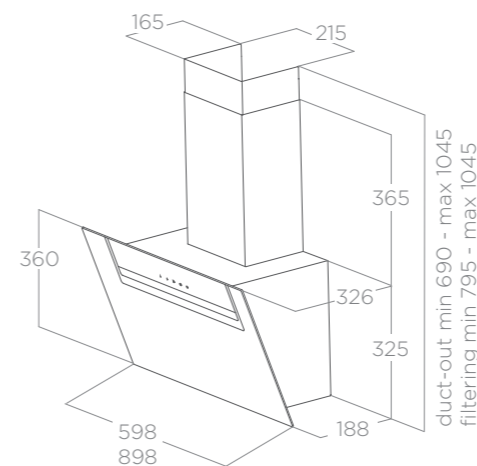

LIGHTING	
Type	LED 2x1,5 W
Intensity	180 lux
Temperature	3500 K
SPECIFICATION	
Controls	Capacitive touch control
Speeds	3 speeds + boost
Booster airflow	650 m ³ /h
Noise level	65 dBA
Total absorption	233 W
Duct size	150
Energy class	A
Aluminium grease filter	Included
Chimney kit	Included

OPTIONAL ACCESSORIES	
Charcoal filter	CFC0140343
Re-circulating kit 1st installation	KIT0160286
Regeneratable filter	CFC0162221

MODELS	
SHEEN-S 60 Black	PRF0166928
SHEEN-S 90 Black	PRF0166929
SHEEN-S 60 White	PRF0166930
SHEEN-S 90 White	PRF0166931



ASCENT

ELICA DESIGN CENTER

60 - 80 - 90 cm
Duct-out/Re-circulating
Black glass, white glass, stainless steel

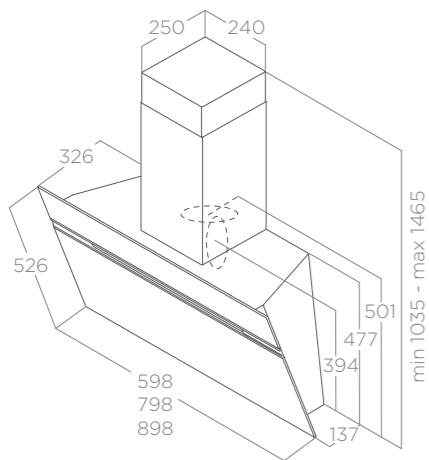

LIGHTING	
Type	LED 2 x 2,5 W
Intensity	203 lux
Temperature	3000 K

SPECIFICATION	
Controls	Capacitive touch control
Speeds	3 speeds + boost
Booster airflow	755 m³/h
Noise level	65 dBA
Total power absorption	265 W
Duct size	150 mm
Energy class	B
Aluminium grease filter	Included
Chimney kit	Included

OPTIONAL ACCESSORIES	
Charcoal filter	CFC0140343
Regeneratable filter	CFC0162221

MODELS	
ASCENT 60 Black	PRF0101142B
ASCENT 60 White	PRF0101144B
ASCENT 60 Stainless steel	PRF0110514B
ASCENT 80 Black	PRF0164806
ASCENT 80 White	PRF0164805
ASCENT 90 Black	PRF0101143B
ASCENT 90 White	PRF0101145B
ASCENT 90 Stainless steel	PRF0110515B

ASCENT URBAN

ELICA DESIGN CENTER

90 cm
Duct-out/Re-circulating
Cast iron effect - Zinc coating effect

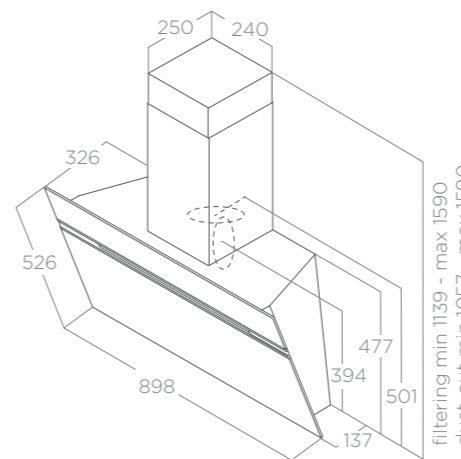

LIGHTING	
Type	LED 2 x 2,5 W
Intensity	381 lux
Temperature	3500 K

SPECIFICATION	
Controls	Touch Control
Speeds	3 speeds + boost
Booster airflow	755 m³/h
Noise level	65 dBA
Total power absorption	265 W
Duct size	150 mm
Energy class	B
Aluminium grease filter	Included
Chimney kit	Included

OPTIONAL ACCESSORIES	
Charcoal filter	CFC0140343
Regeneratable filter	CFC0162221

MODELS	
ASCENT URBAN Iron effect	PRF0147738
ASCENT URBAN Zinc coated effect	PRF0147739

HAIKU

DESIGN FABRIZIO CRISÀ



SHIFT 3238 SYSTEM

FLUSH FIT

Elica is the first to offer a range of cooker hoods that have an adjustable depth system - SHIFT 3238 - so they can be installed flush with a wide range of units from 32cm to 38cm deep. The unique wall mounted bracket is simple to install and easy to adjust to the millimetre. With SHiFT 3238 design limitations disappear and solutions multiply.

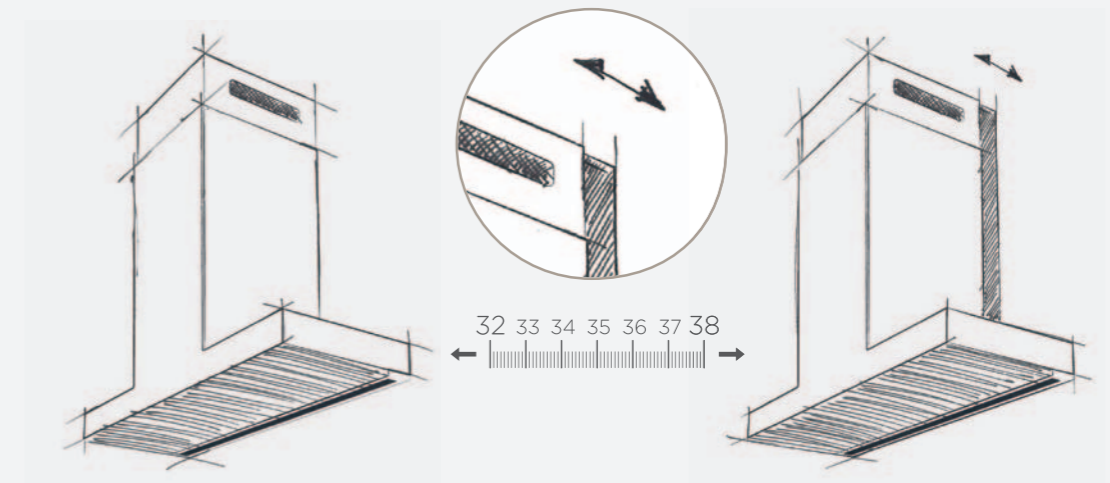



HAIKU BLACK



HAIKU

DESIGN FABRIZIO CRISA

32 - 60 - 90 - 120 cm
Duct-out / Re-circulating
Black glass, white Krion, stainless steel

As well as SHIFT 3238 Haiku can be installed in duct-out or re-circulating mode without the upper chimney section giving a minimum height of only 680mm which is really useful in kitchens with low ceilings.

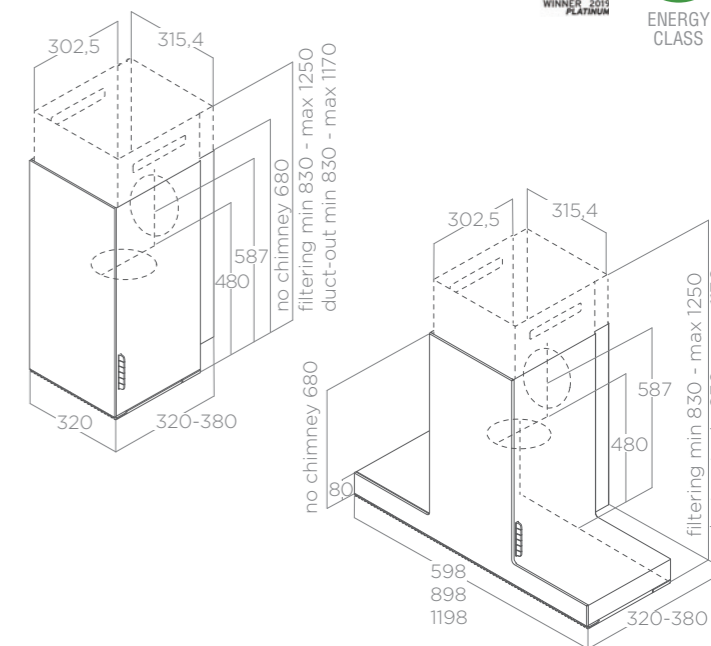

LIGHTING

Type	Strip LED 1x7 W
Intensity	253 lux
Temperature	3500 K

SPECIFICATION

Controls	Touch control
Speeds	3 speeds + 2 boost levels
Booster airflow	690 m³/h
Noise level	51dBA
Total power absorption	277 W
Duct size	150 mm
Energy class	A
Aluminium grease filter	Included



OPTIONAL ACCESSORIES

Standard charcoal filter	CFC0141529A
Regeneratable filter	CFC0141725A

MODELS

HAIKU 32 Black	PRF0146263
HAIKU 32 White	PRF0146267
HAIKU 32 Stainless steel	PRF0146254
HAIKU 60 Black	PRF0146264
HAIKU 60 White	PRF0146268
HAIKU 60 Stainless steel	PRF0146255
HAIKU 90 Black	PRF0146265
HAIKU 90 White	PRF0146269
HAIKU 90 Stainless steel	PRF0146256
HAIKU 120 Black	PRF0146266
HAIKU 120 White	PRF0146270
HAIKU 120 Stainless steel	PRF0146257



HAIKU STAINLESS STEEL

HAIKU WHITE

BIO

DESIGN FABRIZIO CRISÀ





WITH OPTIONAL SHELF



BIO

DESIGN FABRIZIO CRISÀ



90 cm
Duct-out / Re-circulating
Natural oak + white soft touch effect

Bio has a unique combination of natural oak and soft white finishes. The hood has a support and USB charge point for a tablet or phone – the perfect place to display your recipe.

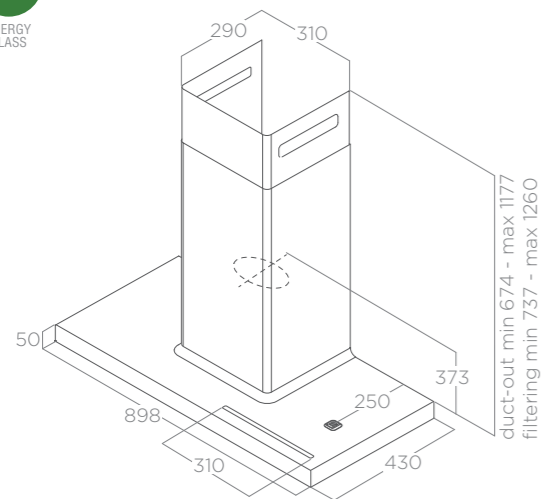

LIGHTING	
Type	Strip LED 1x7 W
Intensity	141 lux
Temperature	2700K - 6500 K

SPECIFICATION	
Controls	Touch Control
Speeds	3 speeds + 2 boost levels
Booster airflow	757 m³/h
Noise level	60 dBA
Total power absorption	317 W
Duct size	150 mm
Energy class	A+
Aluminium grease filter	Included

OPTIONAL ACCESSORIES	
Shelf kit 60cm	KIT0120946
White remote control	KIT0121468
Black remote control	KIT0121469
Revolution filter	CFC0140091
Regeneratable filter	CFC0141725A
Recirculating kit first installation	KIT0160440

MODELS	
BIO	PRF0147266

THIN

DESIGN FABRIZIO CRISÀ

60 - 70 - 90 - 120 cm
Duct-out / Re-circulating
Stainless steel

Ultra thin design of the classic T shaped hood.

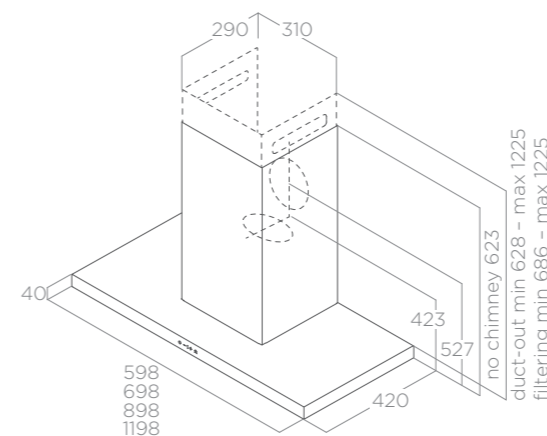

LIGHTING	
Type	Strip LED 1x7 W
Intensity	477 lux
Temperature	3500 K

SPECIFICATION	
Controls	Infrared touch control
Speeds	3 speeds + 2 booster levels
Booster airflow	680 m³/h
Noise level	52 dBA
Total power absorption	277 W
Duct size	150 mm
Energy class	A
Aluminium grease filter	Included

OPTIONAL ACCESSORIES	
Charcoal filter	CFC0141529A
Regeneratable filter	CFC0141725A

MODELS	
THIN 60	PRF0144970
THIN 70	PRF0144971
THIN 90	PRF0144969
THIN 120	PRF0144972



ADÉLE

DESIGN FABRIZIO CRISA

60 - 90 cm
Duct-out / Re-circulating
Stainless steel + black glass, black soft touch effect + black glass



LIGHTING

Type	Strip LED 1x7 W
Intensity	421 lux
Temperature	3000 K

SPECIFICATION

Controls	Capacitive touch control
Speeds	3 speeds + boost
Booster airflow	770 m³/h
Noise level	69 dBA
Total power absorption	277 W
Duct size	150 mm
Energy class	A
Aluminium grease filter	Included

OPTIONAL ACCESSORIES

Charcoal filter	CFC0141529A
Regeneratable filter	CFC0141725A

MODELS

ADÉLE Black stainless steel 60	PRF0167314
ADÉLE Black stainless steel 90	PRF0167315
ADÉLE Black matt 60	PRF0167318
ADÉLE Black matt 90	PRF0167317

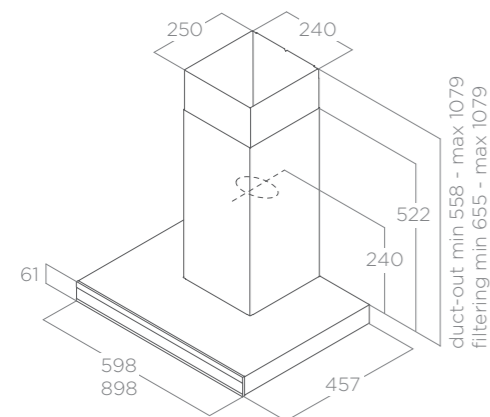

METEORITE

DESIGN FABRIZIO CRISA

90 - 120 cm
Duct-out / Re-circulating
Stainless steel + black glass

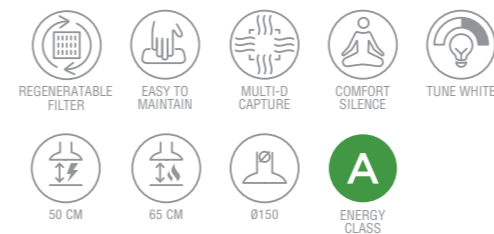

LIGHTING

Type	Strip LED 1x7 W
Intensity	141 lux
Temperature	2700K - 6500 K

SPECIFICATION

Controls	Capacitive touch control
Speeds	3 speeds + 2 booster levels
Booster airflow	757 m³/h
Noise level	60 dBA
Total power absorption	317 W
Duct size	150 mm
Energy class	A
Aluminium grease filter	Included

OPTIONAL ACCESSORIES

Revolution filter	CFC0140091
Regeneratable filter	CFC0141725A
Recirculating kit first installation	KIT0160440
White remote control	KIT0121468
Black remote control	KIT0121469

MODELS

METEORITE 90	PRF0147272
METEORITE 120	PRF0147273

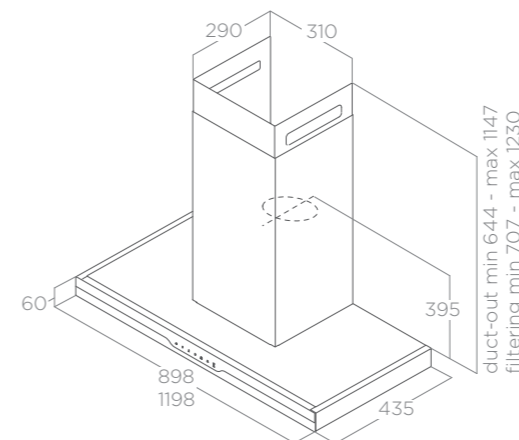



GALAXY

ELICA DESIGN CENTER

80 cm
Duct-out / Re-circulating
Stainless steel + white glass/black glass

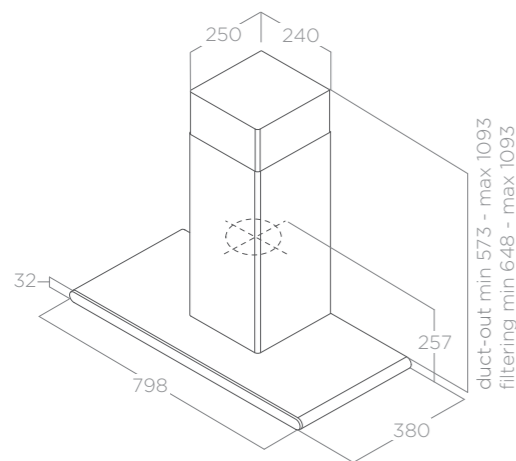
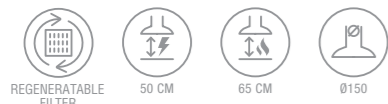

duct-out min 573 - max 1093
filtering min 648 - max 1093

LIGHTING

Type	LED 2x2,5 W
Intensity	145 lux
Temperature	3500 K

SPECIFICATION

Controls	Capacitive touch control
Speeds	3 speeds + boost
Booster airflow	645 m ³ /h
Noise level	71 dBA
Total power absorption	265 W
Duct size	150 mm
Energy class	C
Aluminium grease filter	Included

OPTIONAL ACCESSORIES

Charcoal filter	CFC0141529A
Regeneratable filter	CFC0141725A

MODELS

GALAXY LED Black	PRF0008948B
GALAXY LED White	PRF0009822B



CLAIRE

ELICA DESIGN CENTER

60 - 90 cm
Duct-out / Re-circulating
Stainless steel + black glass

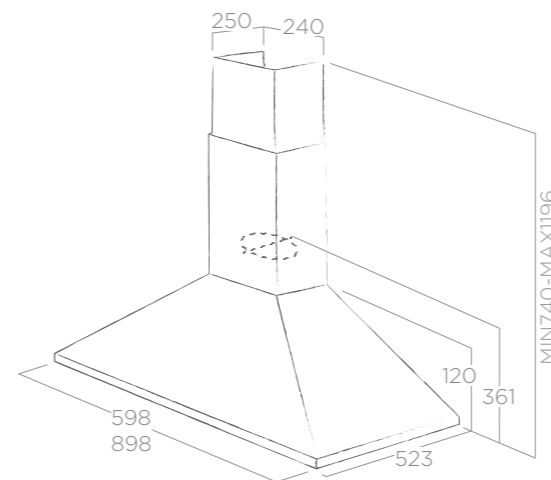

LIGHTING

Type	LED 2x2,5 W
Intensity	145 lux
Temperature	3500 K

SPECIFICATION

Controls	Touch Control
Speeds	3 speeds + boost
Booster airflow	713 m ³ /h
Noise level	69 dBA
Total power absorption	265 W
Duct size	150 mm
Energy class	B
Aluminium grease filter	Included

OPTIONAL ACCESSORIES

Charcoal filter	CFC0141529
Long life filter	CFC0141725

MODELS

CLAIRE 60	PRF0110509
CLAIRE 90	PRF0110510



DOLCE

DESIGN FABRIZIO CRISÀ



85 cm
Duct-out / Re-circulating
Painted: matt white, matt umber, ivory, cast iron, matt copper, peltrox

The use of engineering plastics makes it possible to create the soft contours typical of the Dolce design.

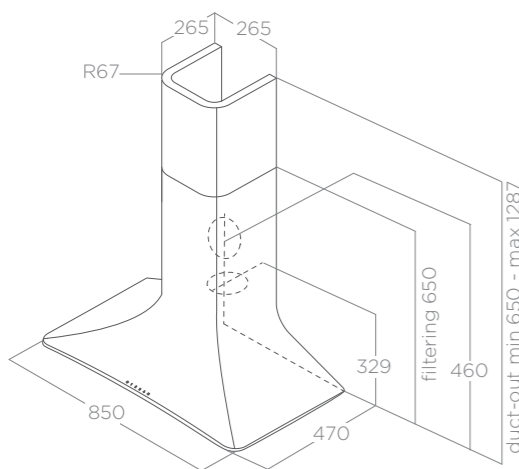

LIGHTING	
Type	Strip LED 1x7 W
Intensity	197 lux
Temperature	4000 K

SPECIFICATION	
Controls	Infrared Touch Control
Speeds	3 speeds + boost
Booster airflow	580 m³/h
Noise level	61 dBA
Total power absorption	257 W
Duct size	150 mm
Energy class	A
Aluminium grease filter	Included
Regeneratable filter	Included

OPTIONAL ACCESSORIES	
Chimney kit white	KIT0049580
Chimney kit umber	KIT0049581
Chimney kit ivory	KIT0049583
Chimney kit cast iron	KIT0121142
Chimney kit copper	KIT0121147
Chimney kit peltrox	KIT0121146

MODELS		
	With chimney extension	Without chimney extension
DOLCE White	PRF0167320	PRF0043030A
DOLCE Umber	PRF0167321	PRF0043031A
DOLCE Ivory	PRF0167322	PRF0043033A
DOLCE Cast Iron	PRF0167319	PRF0120702A
DOLCE Copper	PRF0167324	PRF0120672A
DOLCE Peltrox	PRF0167323	PRF0120689A



ALPHA

ELICA DESIGN CENTER

60 - 90 cm
Duct-out/Re-circulating
Stainless steel, embossed black steel

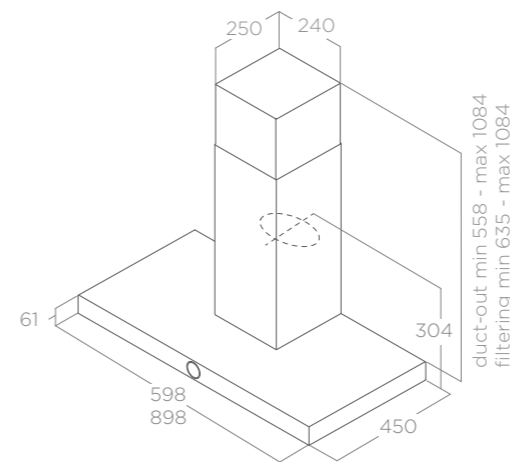

LIGHTING	
Type	LED 2 x 2,5 W
Intensity	381 lux
Temperature	3500 K

SPECIFICATION	
Controls	Electronic Rotative
Speeds	3 speed + boost
Booster airflow	620 m³/h
Noise level	67 dBA
Total power absorption	205 W
Duct size	150 mm
Energy class	A
Aluminium grease filter	Included

OPTIONAL ACCESSORIES	
Charcoal filter	CFC0141529A
Regeneratable filter	CFC0141725A
Chimney kit H.810 stainless steel	KIT00780

MODELS	
ALPHA 60 Stainless steel	PRF0097149A
ALPHA 90 Stainless steel	PRF0097323A
ALPHA 60 Black	PRF0097782A
ALPHA 90 Black	PRF0097906A



CRUISE

ELICA DESIGN CENTER

60 - 90 cm
Duct-out/Re-circulating
Stainless steel

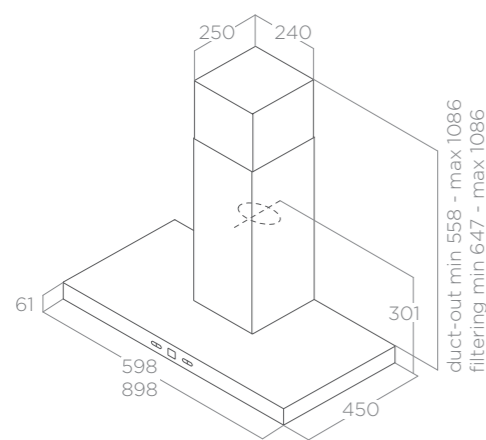
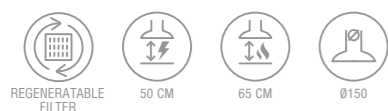

LIGHTING	
Type	LED 2 x 2,5 W
Intensity	145 lux
Temperature	3500 K

SPECIFICATION	
Controls	Touch Control with display
Speeds	3 speeds + boost
Booster airflow	713 m ³ /h
Noise level	69 dBA
Total power absorption	265W
Duct size	150 mm
Energy class	B
Aluminium grease filter	Included

OPTIONAL ACCESSORIES	
Charcoal filter	CFC0141529A
Regeneratable filter	CFC0141725A

MODELS	
CRUISE 60	PRF0147062
CRUISE 90	PRF0147074

JOY

ELICA DESIGN CENTER

60 - 90 cm
Duct-out/Re-circulating
Stainless steel + white glass, stainless steel + black glass

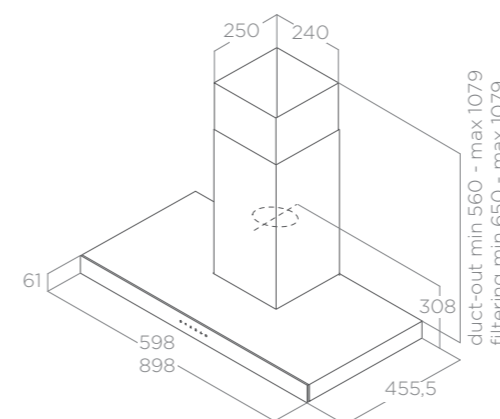

LIGHTING	
Type	LED 2 x 2,5 W
Intensity	381 lux
Temperature	3500 K

SPECIFICATION	
Controls	Capacitive touch control
Speeds	3 speeds + boost
Booster airflow	713 m ³ /h
Noise level	69 dBA
Total power absorption	265 W
Duct size	150 mm
Energy class	B
Aluminium grease filter	Included

OPTIONAL ACCESSORIES	
Charcoal filter	CFC0141529A
Regeneratable filter	CFC0141725A

MODELS	
JOY 60 Black	PRF0104625A
JOY 90 Black	PRF0104626A
JOY 60 White	PRF0104630A
JOY 90 White	PRF0104631A



TRIBE A

ELICA DESIGN CENTER

60 - 90 cm
Duct-out/Re-circulating
Stainless steel + glass

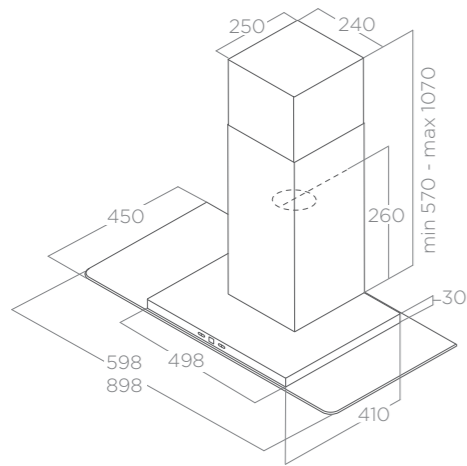

LIGHTING	
Type	LED 2 x 2,5 W
Intensity	381 lux
Temperature	3000 K

SPECIFICATION	
Controls	Touch Control with display
Speeds	3 speeds + boost
Booster airflow	600 m³/h
Noise level	64 dBA
Total power absorption	205 W
Duct size	150 mm
Energy class	A
Aluminium grease filter	Included

OPTIONAL ACCESSORIES	
Charcoal filter	CFC0141529A
Regeneratable filter	CFC0141725A

MODELS	
TRIBE A 60	PRF0150292
TRIBE A 90	PRF0150291

REEF A

ELICA DESIGN CENTER

60 - 90 cm
Duct-out/Re-circulating
Stainless steel + glass

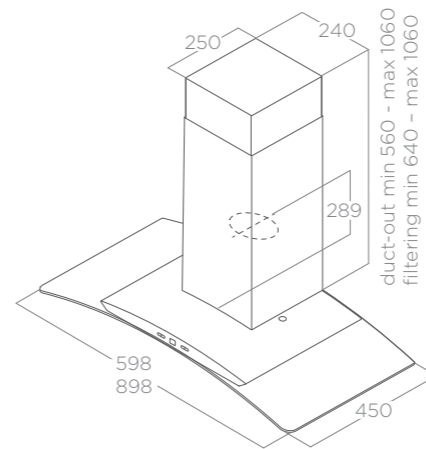

LIGHTING	
Type	LED 2 x 2,5 W
Intensity	381 lux
Temperature	3000 K

SPECIFICATION	
Controls	Touch Control with display
Speeds	3 speed + boost
Booster airflow	600 m³/h
Noise level	64 dBA
Total power absorption	205 W
Duct size	150 mm
Energy class	A
Aluminium grease filter	Included

OPTIONAL ACCESSORIES	
Charcoal filter	CFC0141529A
Regeneratable filter	CFC0141725A

MODELS	
REEF A 60	PRF0150289
REEF A 90	PRF0150288



STONE

ELICA DESIGN CENTER

Diameter 33 cm
Duct-out/Re-circulating
Stainless steel, white

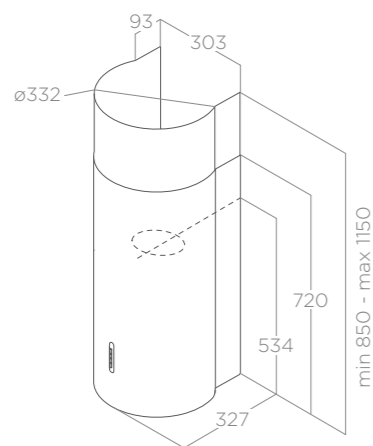
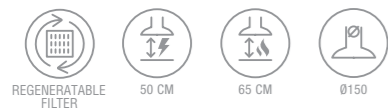

LIGHTING	
Type	LED 2 x 2,5 W
Intensity	457 lux
Temperature	2700 K

SPECIFICATION	
Controls	Soft light Push Button
Speeds	3 speeds
Max airflow	559 m³/h
Noise level	70 dBA
Total power absorption	180 W
Duct size	150 mm
Energy class	C
Aluminium grease filter	Included

OPTIONAL ACCESSORIES	
Charcoal filter	CFC0141529A
Regeneratable filter	CFC0141725A

MODELS	
STONE Stainless steel	61412862B
STONE White	PRF0007123A

TONDA

ELICA DESIGN CENTER

60 - 90 cm
Duct-out/Re-circulating
Stainless steel

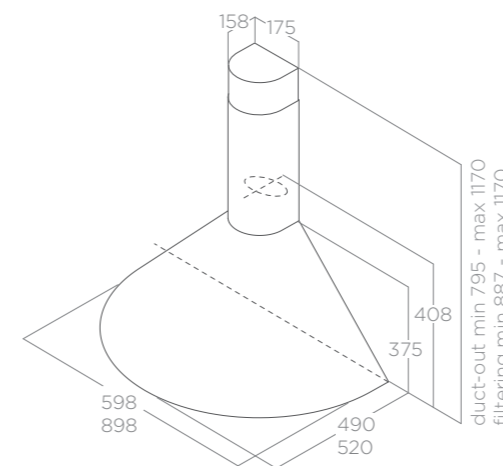

LIGHTING	
Type	LED 2 x 3 W
Intensity	97 lux
Temperature	2700 K

SPECIFICATION	
Controls	Slider
Speeds	3 speeds
Max airflow	355 m³/h
Noise level	67 dBA
Total power absorption	146 W
Duct size	120 mm
Energy class	D
Aluminium grease filter	Included
Charcoal filter	Included

MODELS	
TONDA 60	2938000C
TONDA 90	2937999C

TAMAYA HP

ELICA DESIGN CENTER

60 - 90 cm
Duct-out/Re-circulating
Stainless steel

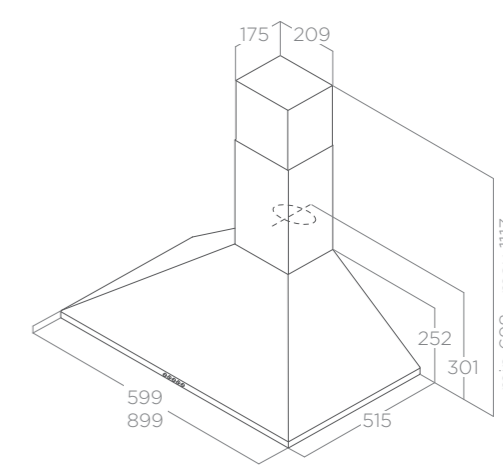

LIGHTING	
Type	LED 2 x 2,5 W
Intensity	381 lux
Temperature	3500 K

SPECIFICATION	
Controls	Touch control with display
Speeds	3 speeds + boost
Booster airflow	730 m³/h
Noise level	64 dBA
Total power absorption	255 W
Duct size	150 mm
Energy class	C
Aluminium grease filter	Included

OPTIONAL ACCESSORIES	
Charcoal filter	CFC0140124
Chimney extension kit +390mm	KIT00778/A
Chimney extension kit +610mm	KIT00779/A

MODELS	
TAMAYA 60 HP	PRF0009991A
TAMAYA 90 HP	PRF0009989A



AQUAVITAE

ELICA DESIGN CENTER

50 - 60 - 70 - 90 cm
Duct-out/Re-circulating
Stainless steel



50 CM

65 CM

Ø120

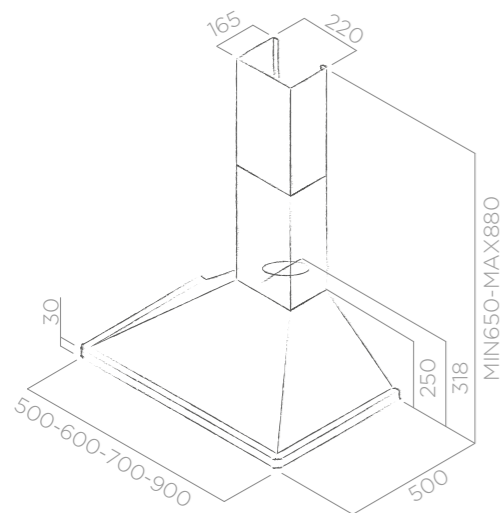

LIGHTING

Type	LED 2 x 3 W
Intensity	49 lux
Temperature	2700 K

SPECIFICATION

Controls	Mechanical push button
Speeds	3 speeds
Max airflow	320 m ³ /h
Noise level	68 dBA
Total power absorption	96 W
Duct size	120 mm
Energy class	D
Aluminium grease filter	Included

OPTIONAL ACCESSORIES

Charcoal filter	CFC0157821
-----------------	------------

MODELS

AQUAVITAE 50	PRF0061486B
AQUAVITAE 60	PRF0061480B
AQUAVITAE 70	PRF0061476B
AQUAVITAE 90	PRF0061463B



ACUTA

ELICA DESIGN CENTER



100 cm
Duct-out/Re-circulating
Stainless steel



REGENERATABLE FILTER

50 CM

65 CM

Ø150

ENERGY CLASS

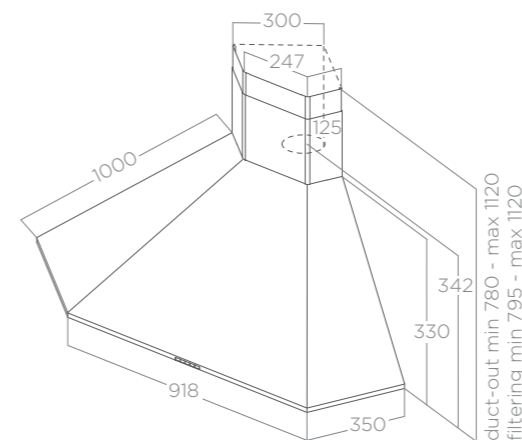

LIGHTING

Type	LED 4 x 2,5 W
Intensity	441 lux
Temperature	3500 K

SPECIFICATION

Controls	Touch control
Speeds	3 speeds + boost
Booster airflow	625 m ³ /h
Noise level	60 dBA
Total power absorption	210 W
Duct size	150 mm
Energy class	A
Aluminium grease filter	Included
Charcoal filter	Included

OPTIONAL ACCESSORIES

Regeneratable filter	CFC0162221
----------------------	------------

MODELS

ACUTA	PRF0121267A
-------	-------------

ISLAND





HAIKU ISLAND

DESIGN FABRIZIO CRISA



32 x 32 - 120 x 32 - 180 x 32 cm
 Duct-out / Re-circulating
 Black glass, white Krion, stainless steel

KRION® is a high performance material that's warm to the touch but otherwise similar to natural stone. It is comprised of two thirds natural minerals and high-resistance resins. This makes it very attractive, antibacterial and extremely durable.



LIGHTING

Type	Strip LED 1x7 W
Intensity	281 lux
Temperature	3500 K

SPECIFICATION

Controls	Touch Control
Speeds	3 speeds + 2 boost levels
Booster airflow	690 m³/h
Noise level	51 dBA
Total power absorption	277 W
Duct size	150 mm
Energy class	A
Aluminium grease filter	Included

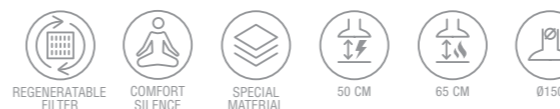
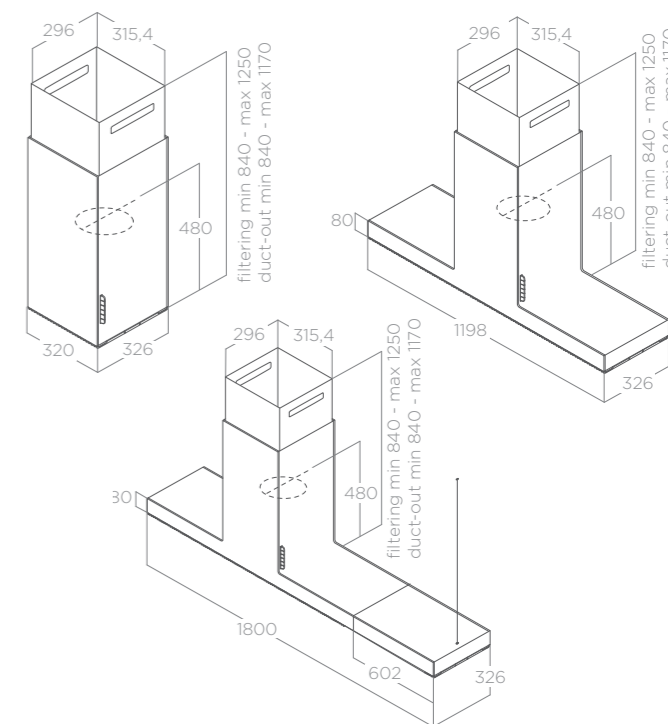

OPTIONAL ACCESSORIES

Charcoal filter	CFC0141529
Regeneratable filter	CFC0141725A

MODELS

HAIKU ISLAND 32 Black	PRF0146285
HAIKU ISLAND 32 White	PRF0146289
HAIKU ISLAND 32 Stainless steel	PRF0146277
HAIKU ISLAND 120 Black	PRF0146286
HAIKU ISLAND 120 White	PRF0146290
HAIKU ISLAND 120 Stainless steel	PRF0146279
HAIKU ISLAND 180 Black	PRF0146287
HAIKU ISLAND 180 White	PRF0146291
HAIKU ISLAND 180 Stainless steel	PRF0146280

YIN

DESIGN FABRIZIO CRISÀ





YIN

DESIGN FABRIZIO CRISÀ

66x42 cm
Duct-out / Re-circulating
White Crystalplant

Crystalplant is a hypoallergenic material that is scratch resistant and tactile. Any surface damage is easily removed with the special abrasive pad supplied.

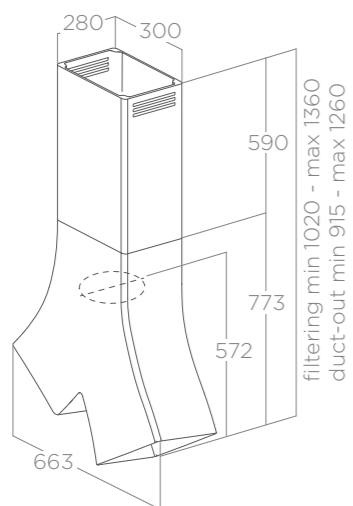
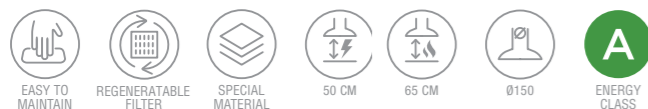

LIGHTING

Type	LED 2x4 W
Intensity	609 lux
Temperature	4000 K

SPECIFICATION

Controls	Remote control (included)
Speeds	3 speed + boost
Booster airflow	625 m³/h
Noise level	61 dBA
Total power absorption	268 W
Duct size	150 mm
Energy class	A

OPTIONAL ACCESSORIES

Regeneratable filter	CFC0141737
----------------------	------------

MODELS

YIN	PRF0098375
-----	------------

THIN ISLAND

DESIGN FABRIZIO CRISÀ

120x57 cm
Duct-out / Re-circulating
Stainless steel

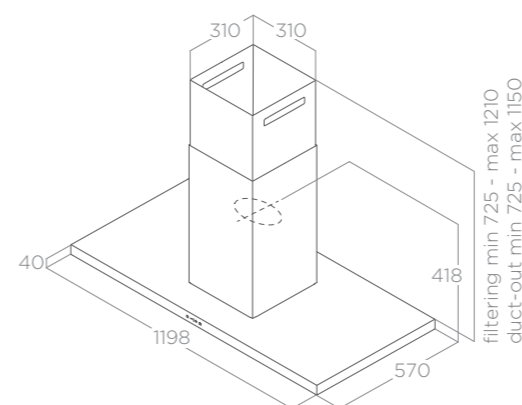
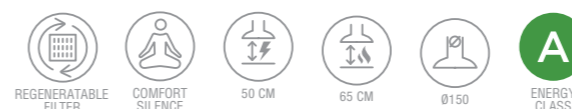

LIGHTING

Type	Strip LED 2 x 7 W
Intensity	253 lux
Temperature	3500 K

SPECIFICATION

Controls	Infrared Touch Control
Speeds	3 speeds + 2 boost levels
Booster airflow	680 m³/h
Noise level	52 dBA
Total power absorption	284 W
Duct size	150 mm
Energy class	A
Aluminium grease filter	Included

OPTIONAL ACCESSORIES

Charcoal filter	CFC0141529A
Regeneratable filter	CFC0141725A

MODELS

THIN ISLAND	PRF0144973
-------------	------------



BIO ISLAND

DESIGN FABRIZIO CRISÀ



120x53 cm
Duct-out / Re-circulating
Natural oak + white soft touch effect

A unique combination of synthetic soft touch materials and a solid oak finish BIO ISLAND and has an integrated support for tablets and smartphones, along with a double USB port just where you need to see a recipe displayed. The optional shelf adds design versatility.

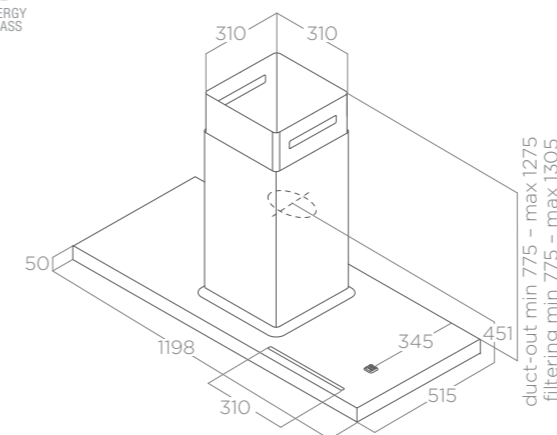
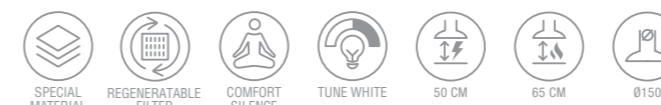

LIGHTING	
Type	Strip LED 2x7 W
Intensity	141 lux
Temperature	2700K - 6500 K

SPECIFICATION	
Controls	Touch Control
Speeds	3 speeds + 2 boost
Booster airflow	757 m³/h
Noise level	60 dBA
Total power absorption	324 W
Duct size	150 mm
Energy class	A+
Aluminium grease filter	Included

OPTIONAL ACCESSORIES	
Shelf kit 60cm	KIT0120947
Cables kit 1,7mt	KIT0120948
White remote control	KIT0121468
Black remote control	KIT0121469
Revolution filter	CFC0140091
Regeneratable filter	CFC0141725A
Recirculating kit 1st installation	KIT0160440

MODELS	
BIO ISLAND	PRF0148081



METEORITE ISLAND

DESIGN FABRIZIO CRISA

120x60 cm
Duct-out / Re-circulating
Stainless steel

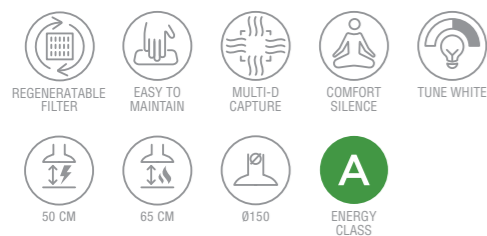

LIGHTING

Type	Strip LED 2x7 W
Intensity	85 lux
Temperature	2700K - 6500 K

SPECIFICATION

Controls	Capacitive touch control
Speeds	3 speeds + 2 boost levels
Booster airflow	800 m ³ /h
Noise level	60 dBA
Total power absorption	324 W
Duct size	150 mm
Energy class	A
Aluminium grease filter	Included

OPTIONAL ACCESSORIES

Revolution filter	CFC0140091
Regeneratable filter	CFC0141725A
Recirculating kit 1st installation	KIT0160440
White remote control	KIT0121468
Black remote control	KIT0121469

MODELS

METEORITE ISLAND	PRF0148122
------------------	------------

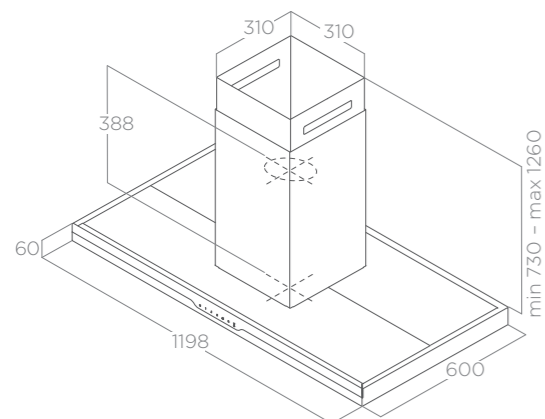

GALAXY ISLAND

ELICA DESIGN CENTER

90x45 cm
Duct-out / Re-circulating
Stainless steel + white glass/black glass



LIGHTING

Type	LED 4x2,5 W
Intensity	290 lux
Temperature	3500 K

SPECIFICATION

Controls	Capacitive touch control
Speeds	3 speeds + boost
Booster airflow	645 m ³ /h
Noise level	69 dBA
Total power absorption	270 W
Duct size	150 mm
Energy class	C
Aluminium grease filter	Included

OPTIONAL ACCESSORIES

Charcoal filter	CFC0141529A
Regeneratable filter	CFC0141725A

MODELS

GALAXY ISLAND LED Black	PRF0017852B
GALAXY ISLAND LED White	PRF0019192B

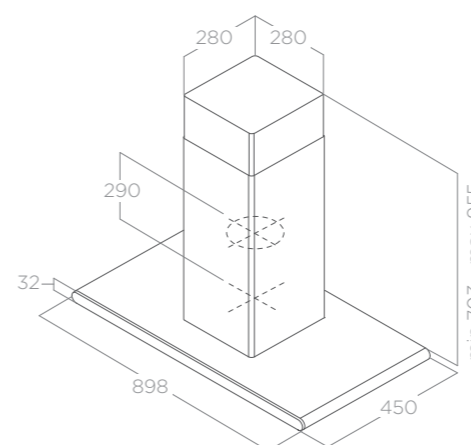



ADÉLE ISLAND

DESIGN FABRIZIO CRISÀ

90x60 cm
Duct-out / Re-circulating
Stainless steel + black glass, black soft touch effect + black glass

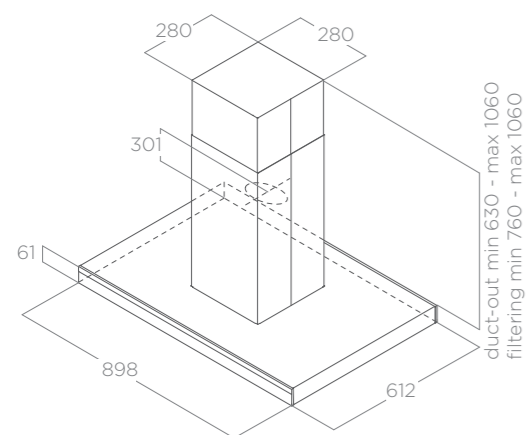

LIGHTING

Type	Strip LED 2x7 W
Intensity	309 lux
Temperature	3000 K

SPECIFICATION

Controls	Capacitive touch control
Speeds	3 speeds + boost
Booster airflow	770 m³/h
Noise level	69 dBA
Total power absorption	277 W
Duct size	150 mm
Energy class	A
Aluminium grease filter	Included

OPTIONAL ACCESSORIES

Charcoal filter	CFC0141529A
Regeneratable filter	CFC0141725A

MODELS

ADÉLE ISLAND Black + stainless steel	PRF0167313
ADÉLE ISLAND Black matt	PRF0167316

TRIBE A ISLAND

ELICA DESIGN CENTER

90x60 cm
Duct-out / Re-circulating
Stainless steel + glass

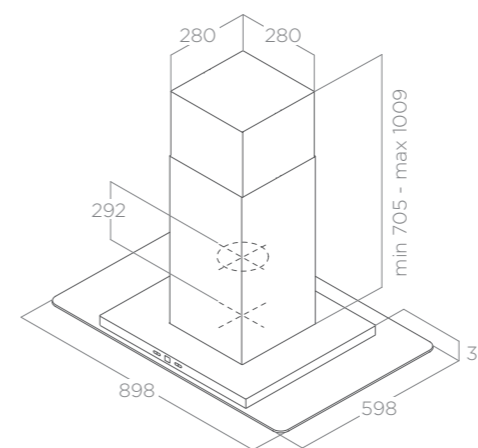

LIGHTING

Type	LED 2 x 2,5 W
Intensity	381 lux
Temperature	3000 K

SPECIFICATION

Controls	Touch control with display
Speeds	3 speeds + boost
Booster airflow	600 m³/h
Noise level	64 dBA
Total power absorption	205 W
Duct size	150 mm
Energy class	A
Aluminium grease filter	Included

OPTIONAL ACCESSORIES

Charcoal filter	CFC0141529A
Regeneratable filter	CFC0141725A

MODELS

TRIBE A ISLAND	PRF0150293
----------------	------------



REEF A ISLAND

ELICA DESIGN CENTER

90x60 cm
Duct-out / Re-circulating
Stainless steel + glass

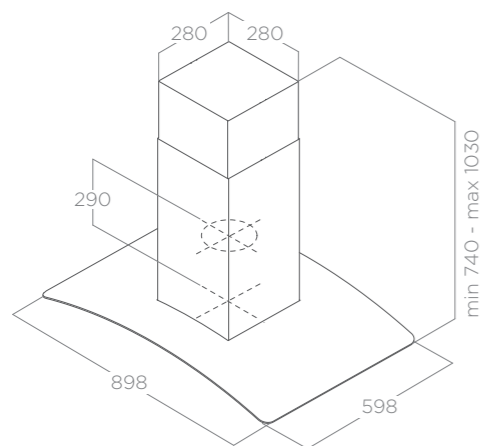

LIGHTING	
Type	LED 2 x 2,5 W
Intensity	381 lux
Temperature	3000 K

SPECIFICATION	
Controls	Touch control with display
Speeds	3 speeds + boost
Booster airflow	600 m ³ /h
Noise level	64 dBA
Total power absorption	205 W
Duct size	150 mm
Energy class	A
Aluminium grease filter	Included

OPTIONAL ACCESSORIES	
Charcoal filter	CFC0141529A
Regeneratable filter	CFC0141725

MODELS	
REEF A ISLAND	PRF0150290



TUBE PRO ISLAND

ELICA DESIGN CENTER

Diameter 43 cm
Duct-out / Re-circulating
Stainless steel, black, white

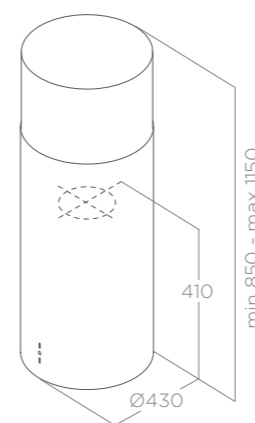
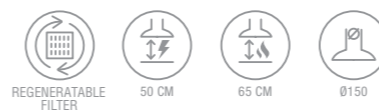

LIGHTING	
Type	LED 2 X 3 W
Intensity	457 lux
Temperature	2700 K

SPECIFICATION	
Controls	Mechanical push button
Speeds	3 speeds
Max airflow	600 m ³ /h
Noise level	68 dBA
Total power absorption	256 W
Duct size	150 mm
Energy class	C
Aluminium grease filter	Included

OPTIONAL ACCESSORIES	
Regeneratable filter	CFC0140423

MODELS	
TUBE PRO ISLAND Stainless steel	PRF0044794B
TUBE PRO ISLAND Black	PRF0090717B
TUBE PRO ISLAND White	PRF0090718B

CEILING





LULLABY

DESIGN FABRIZIO CRISÀ



120x65 cm
Duct-out/Re-circulating
White lacquered wood with stainless steel, Natural oak with white soft touch effect

The recirculating models can be installed without the false ceiling. The central full LED light panel is surrounded by a natural oak frame or white lacquered frame. Matching extension shelves are available as accessories and any type of commercially available light can also be connected.

DUCT-OUT VERSION

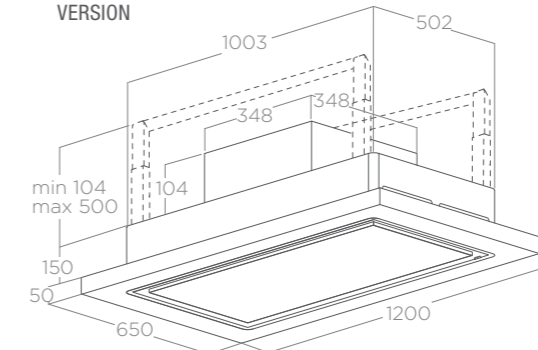

RE-CIRCULATING VERSION

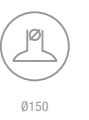
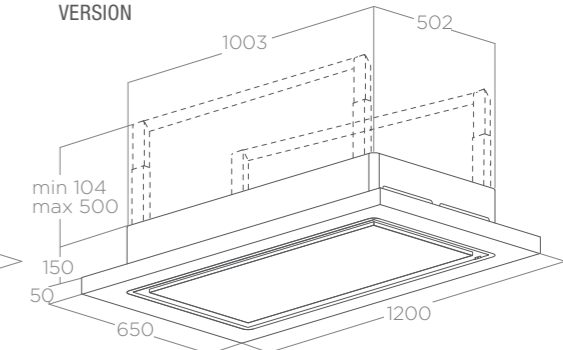

LIGHTING

Type	LED panel 28 W
Intensity	1683 lux
Temperature	2700 - 5000 K

OPTIONAL ACCESSORIES

Shelf kits	See page 118
Lighting accessories	See page 118
Dimmer kit	KIT0147878

SPECIFICATION

Controls	Remote control	
Speeds	3 speeds + 2 boost levels	
	Duct-out	Re-circulating
Maximum boost airflow	770 m ³ /h	483 m ³ /h
Noise level	53 dBA	64 dBA
Total power absorption	188W	214W
Energy class	A	n/a
Duct size	150mm	
Aluminium grease filter	Included	Included
Revolution filter	-	Included
Remote control	Included	Included

MODELS

LULLABY White wood duct-out	PRF0146227
LULLABY White wood re-circulating	PRF0146226
LULLABY Natural wood duct-out	PRF0146229
LULLABY Natural wood re-circulating	PRF0146225
LULLABY @ Natural wood duct out version	PRF0167046
LULLABY @ Natural wood re-circulating version	PRF0167047
LULLABY @ White wood duct out version	PRF0167048
LULLABY @ White wood re-circulating version	PRF0167049

Model not subject to compulsory energy certification. (*)

** with optional recirculating kit see page 119

* LULLABY @ versions with Wifi connectivity available Autumn 2021

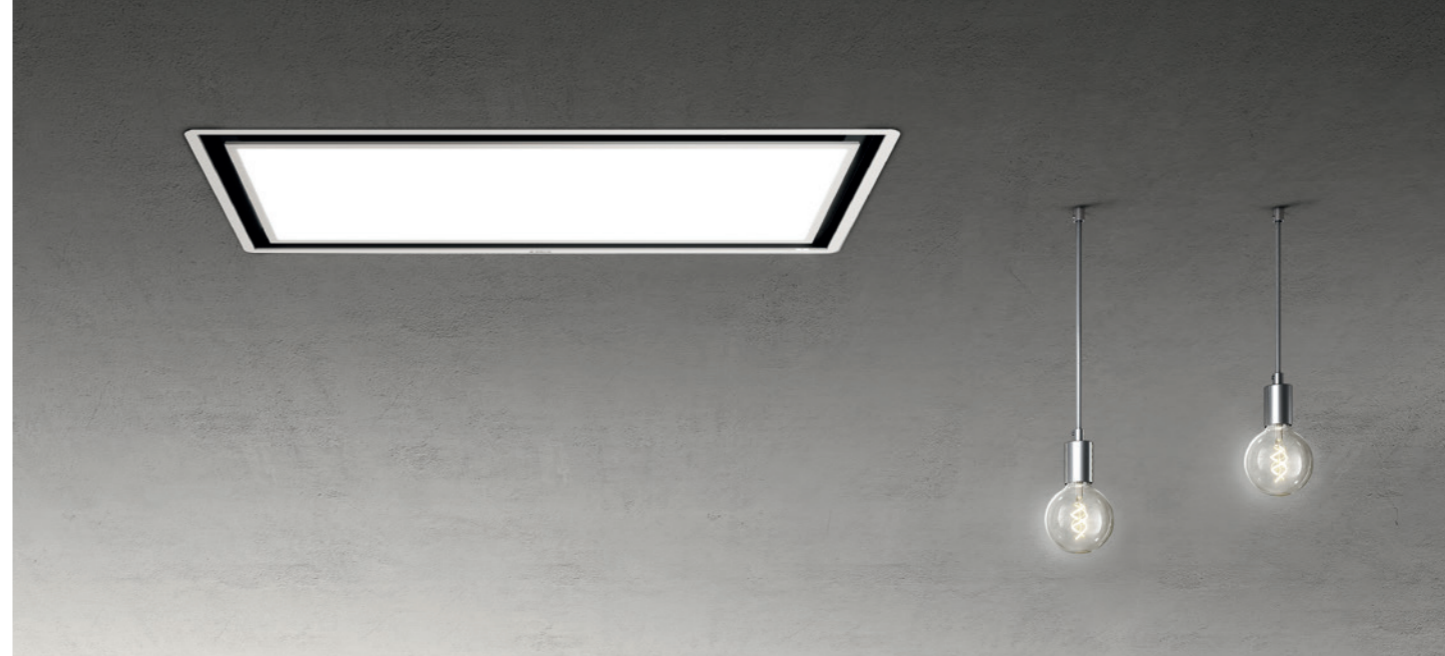

SKYDOME

DESIGN FABRIZIO CRISÀ

100x50 cm
Duct-out/Re-circulating
White

The exclusive slim H16 solution for false ceilings with lower heights has been designed to maintain the excellent extraction properties with low noise levels. The brightness and tone of the light panel can be controlled by a wall-mounted switch or remote control and any commercially available light can be connected.

H16 - NO MOTOR VERSIONS

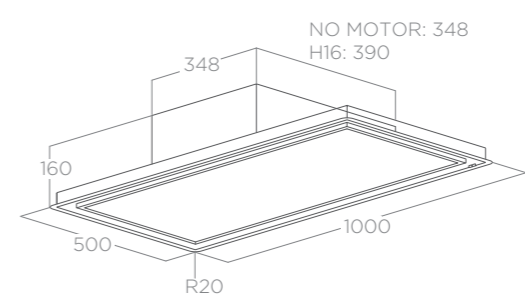

FALSE CEILING CUT: 480X980

H30 VERSION

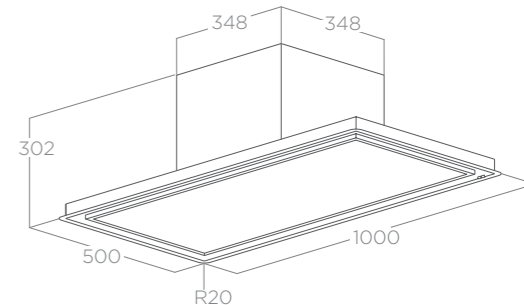

FALSE CEILING CUT: 480X980

- TOTAL INTEGRATION
- HIGH PERFORMANCE REGENERATABLE FILTER **
- REGENERATABLE FILTER **
- SUPER EASY INSTALLATION
- COMFORT SILENCE
- TUNE WHITE
- DIM LIGHT
- H16 25.2 KG
- H30 27.2 KG
- NO MOT 21.7 KG
- Ø150
- ENERGY CLASS A



LIGHTING		
Type	LED panel 28 W	
Intensity	1683 lux	
Temperature	2700 - 5000 K	
SPECIFICATION		
	H16	H30
Controls	Remote control	Remote control
Speeds	3 speeds + 2 boost levels	3 speeds + 2 boost levels
Maximum boost airflow	750 m³/h	770 m³/h
Noise level	68 dBA	53 dBA
Total power absorption	293 W	188 W
Energy class	A (remote motor B)	A
Duct size	222 x 89 mm (int)	150 mm
Aluminium grease filter	Included	Included
Remote control	Included	Included

OPTIONAL ACCESSORIES	
Recycling kit H30	KIT0148449
Recycling kit H16	KIT0148450A
Internal remote motor	KIT0147879
Wall external motor	KIT0147880
Roof external motor	KIT0147881
Inclined roof external motor	KIT0147882
Dimmer kit	KIT0147878
MODELS	
SKYDOME H16 White	PRF0147735A
SKYDOME H30 White	PRF0146232A
SKYDOME Remote motor White	PRF0146230

For remote motors specification see page 180
** with optional recirculating kit see page 119

ILLUSION

DESIGN FABRIZIO CRISÀ





ILLUSION

DESIGN FABRIZIO CRISÀ

100x50 cm
Duct-out/Re-circulating
White + white frame, drywall
compatible + stainless steel frame,
black + black frame

Unique and customisable the model can be finished like the ceiling. The exclusive H16 solution for false ceilings with lower heights has been designed to maintain the excellent extraction properties with low noise levels and any commercially available light can be connected.

H16 - NO MOTOR VERSIONS

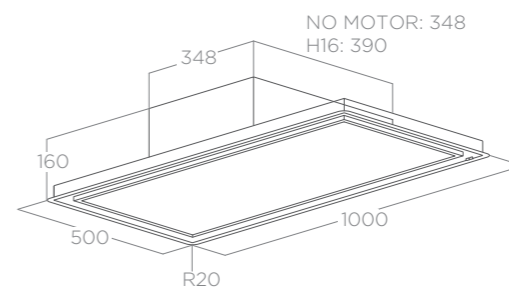

FALSE CEILING CUT: 480X980

H30 VERSION

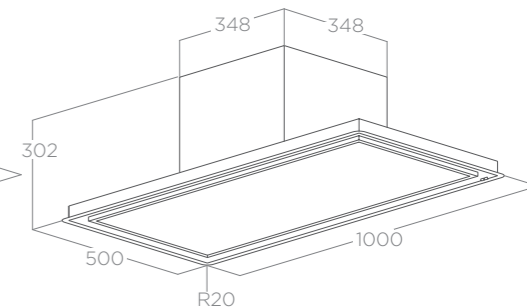

FALSE CEILING CUT: 480X980



LIGHTING

Type	Strip LED 2 x 14 W
Intensity	563 lux
Temperature	2700-5000 K

SPECIFICATION

	H16	H30
Controls	Remote control	Remote control
Speeds	3 speeds + 2 boost levels	3 speeds + 2 boost levels
Maximum boost airflow	750 m ³ /h	770 m ³ /h
Noise level	68 dBA	53 dBA
Total power absorption	293 W	188 W
Duct size	222 x 89 mm (int)	150 mm
Energy class	A (remote motor B)	A
Aluminium grease filter	Included	Included
Remote control	Included	Included

OPTIONAL ACCESSORIES

Recycling kit H30	KIT0148449
Recycling kit H16	KIT0148450A
Internal remote motor	KIT0147879
Wall external motor	KIT0147880
Roof external motor	KIT0147881
Inclined Roof external motor	KIT0147882
Dimmer kit	KIT0147878

MODELS

ILLUSION H30 Customisable	PRF0146250A
ILLUSION H30 White	PRF0146251A
ILLUSION H30 Black	PRF0172646A
ILLUSION H16 Customisable	PRF0147726A
ILLUSION H16 White	PRF0147727A
ILLUSION H16 Black	PRF0172645A
ILLUSION Remote motor customisable	PRF0146252
ILLUSION Remote motor White	PRF0146253

For remote motors specification see page 180
** with optional recirculating kit see page 119

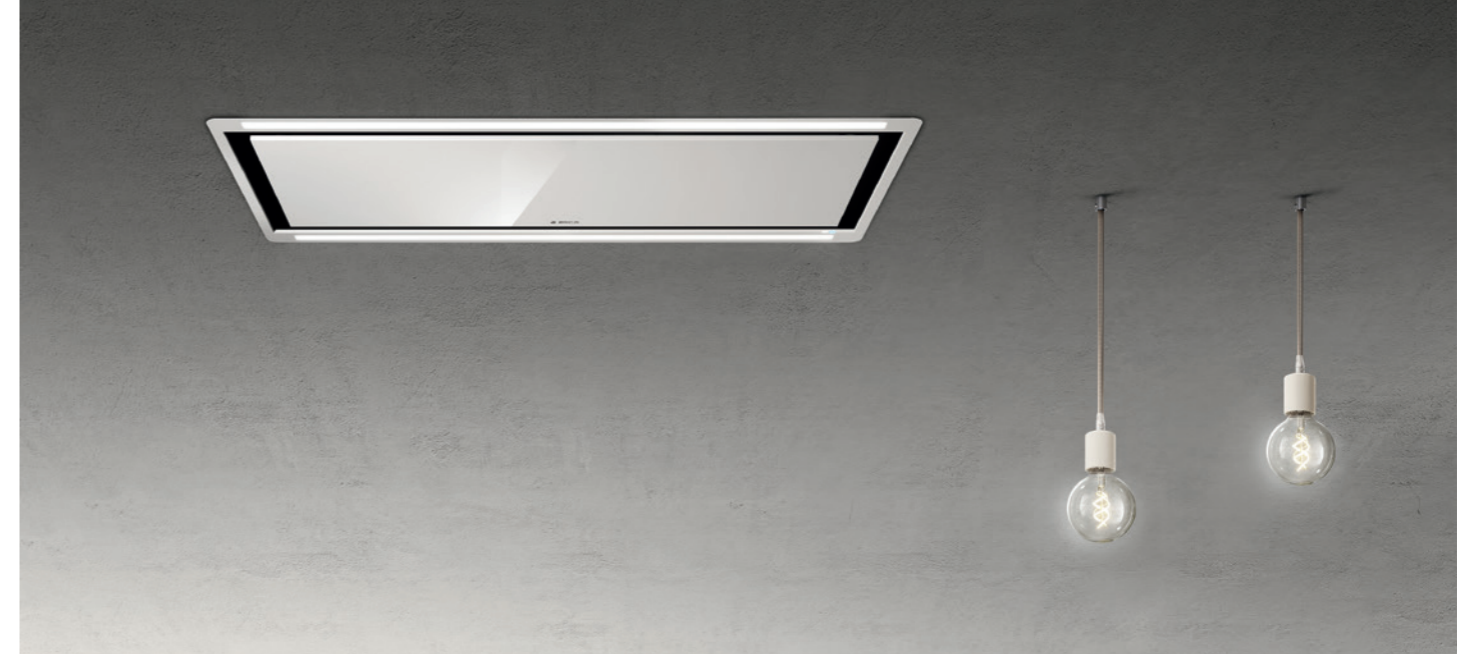

HIGHLIGHT-GLS

DESIGN FABRIZIO CRISÀ

100x57 cm
Duct-out/Re-circulating
Re-circulating kit available
White glass + white frame

The exclusive H16 solution for false ceilings with lower heights has been designed to maintain the excellent extraction properties with low noise levels. The brightness and tone of the light strips can be controlled by a wall-mounted switch or remote control and any commercially available light can be connected.

H16 - NO MOTOR VERSION

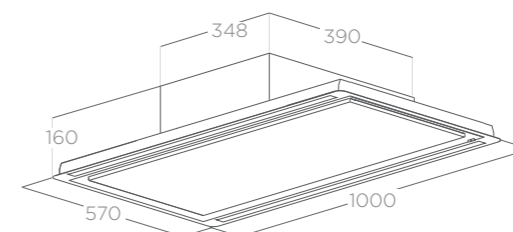

FALSE CEILING CUT: 550X980

H30 VERSION

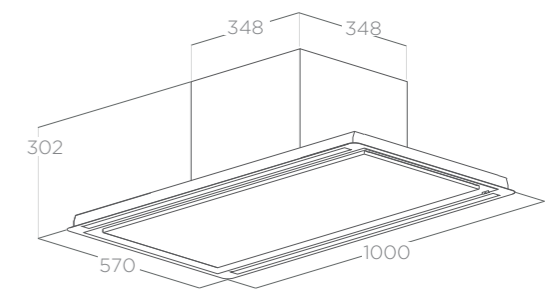

FALSE CEILING CUT: 550X980

- TOTAL INTEGRATION
- HIGH PERFORMANCE REGENERATABLE FILTER **
- REGENERATABLE FILTER **
- SUPER EASY INSTALLATION
- COMFORT SILENCE
- TUNE WHITE
- DIM LIGHT
- H16 31 KG
- H30 34.10 KG
- NO MOT 24.80 KG
- Ø150
- ENERGY CLASS A

LIGHTING	
Type	Strip LED 2 x 14 W
Intensity	563 lux
Temperature	2700-5000 K

SPECIFICATION		
	H16	H30
Controls	Remote control	Remote control
Speeds	3 speeds + 2 boost levels	3 speeds + 2 boost levels
Maximum boost airflow	720 m³/h	790 m³/h
Noise level	69 dBA	53 dBA
Total power absorption	293 W	188 W
Energy class	A (remote motor B)	A
Duct size	222 x 89 mm (int)	150 mm
Aluminium grease filter	Included	Included
Remote control	Included	Included

OPTIONAL ACCESSORIES	
Recycling kit H16	KIT0148450A
Recycling kit H30	KIT0148449
Internal remote motor	KIT0147879
Wall external motor	KIT0147880
Roof external motor	KIT0147881
Inclined Roof external motor	KIT0147882
Dimmer kit	KIT0147878

MODELS	
HIGHLIGHT-GLS Remote motor white glass	PRF0146248
HIGHLIGHT-GLS H30 White glass	PRF0146246A
HIGHLIGHT-GLS H16 White glass	PRF0167044A

For remote motors specification see page 180
** with optional recirculating kit see page 119



HILIGHT-X

DESIGN FABRIZIO CRISÀ

100x57 cm
 Duct-out/Re-circulating
 Re-circulating kit available
 Stainless steel, black, white

The exclusive H16 solution for false ceilings with lower heights has been designed to maintain the excellent extraction properties with low noise levels.

H16 - NO MOTOR VERSION

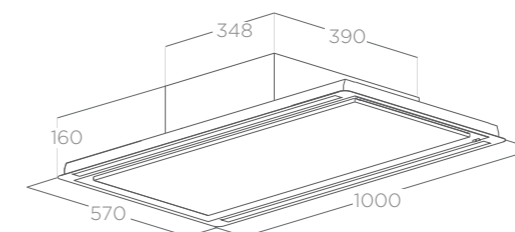

FALSE CEILING CUT: 550X980

H30 VERSION

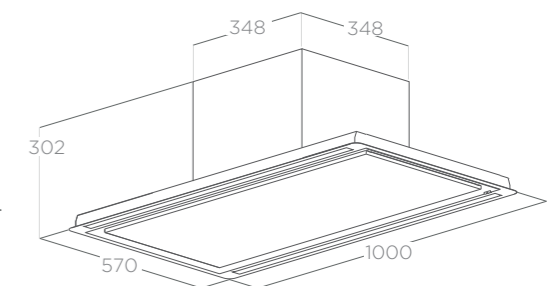

FALSE CEILING CUT: 550X980



LIGHTING

Type	Strip LED 2 x 14 W
Intensity	563 lux
Temperature	2700-5000 K

SPECIFICATION

	H16	H30
Controls	Remote control	Remote control
Speeds	3 speeds + 2 boost levels	3 speeds + 2 boost levels
Maximum boost airflow	720 m³/h	780 m³/h
Noise level	69 dBA	63 dBA
Total power absorption	279 W	324 W
Energy class	A (remote motor B)	A
Duct size	222 x 89 mm (int)	150 mm
Aluminium grease filter	Included	Included
Remote control	Included	Included

OPTIONAL ACCESSORIES

Recycling kit H16	KIT0148450A
Recycling kit H30	KIT0148449
Internal remote motor	KIT0147879
Wall external motor	KIT0147880
Roof external motor	KIT0147881
Inclined Roof external motor	KIT0147882
Dimmer kit	KIT0147878

MODELS

HILIGHT-X H16 Stainless steel	PRF0167045A
HILIGHT-X H16 White lacquer	PRF0173442A
HILIGHT-X H16 Black lacquer	PRF0173443A
HILIGHT-X H30 Stainless steel	PRF0163520A
HILIGHT-X H30 White lacquer	PRF0173444A
HILIGHT-X H30 Black lacquer	PRF0173445A
HILIGHT-X Remote motor Stainless steel	PRF0163523

For remote motors specification see page 180

** with optional recirculating kit see page 119



FILTERING VERSION



DUCT-OUT VERSION



CLOUD SEVEN

DESIGN FABRIZIO CRISÀ

90 cm x 50cm
Duct-out/Re-circulating
Stainless steel

Plug&Play model, easy-to-install,
no need for building work on
gypsum panels or additional pipes
(Cloud Seven Filter).

DUCT-OUT VERSION

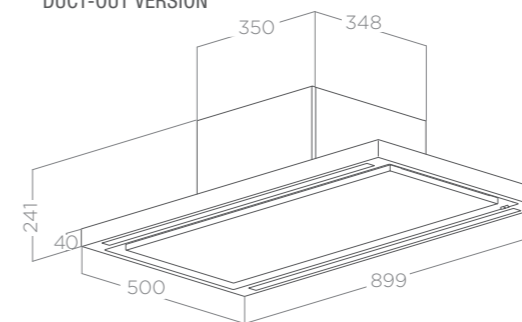

RE-CIRCULATING VERSION

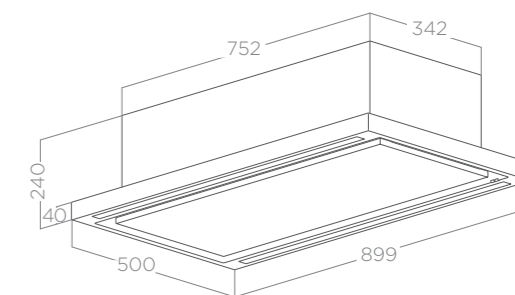

FALSE CEILING CUT: 480X880



LIGHTING

Type	Strip LED 2 X 7 W
Intensity	393 lux
Temperature	3500 K

MODELS

CLOUD SEVEN Duct-out	PRF0142094A
CLOUD SEVEN Re-circulating	PRF0141953

SPECIFICATION

	Duct-out	Re-circulating
Controls	Remote control	Remote control
Speeds	3 speeds + boost	3 speeds + boost
Maximum boost airflow	770 m³/h	570 m³/h
Noise level	60 dBA	69 dBA
Total power absorption	284 W	214 W
Energy class	A	N/A
Duct size	150 mm	-
Aluminium grease filter	Included	Included
Regeneratable filter	-	Included
Remote control	Included	Included

** with optional recirculating kit see page 119

ACCESSORIES

SHELF KITS

SHELF KIT LULLABY (WHITE)
KIT0147859



SHELF KIT LULLABY (WOOD)
KIT0147858

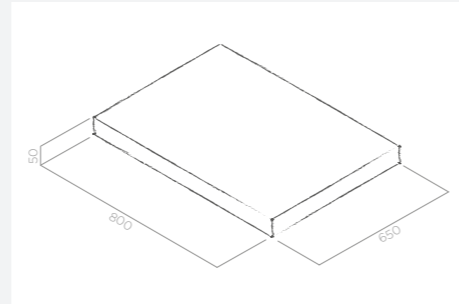

LAMPS



LED BULB
GOLDEN SPHERE
XXL
KIT0147862

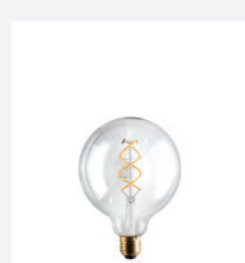

LED BULB
TRANSPARENT
KIT0147863

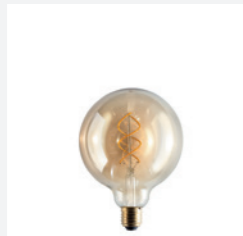

LED BULB
GOLDEN
KIT0147864

WIRING AND LAMP HOLDER



LIGHTING KIT COPPER GRAY



KIT0147867



LIGHTING KIT JUTE



KIT0147875

Our ceiling hoods use the same ducting as our NikolaTesla duct-out hoods - see page 34

CARBON FILTERS KIT

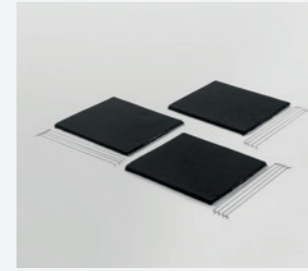

KIT0148449
Recycling kit H30 models:
HILIGHT-X H30
HILIGHT-GLS H30
ILLUSION H30
SKYDOME H30
LULLABY DUCT-OUT VERS.



KIT0148450A
High performance recirculating
kit for:
CLOUD SEVEN DUCT-OUT
VERS.
HILIGHT-X H16
HILIGHT-GLS H16
HILIGHT-X H30
HILIGHT-GLS H30
ILLUSION H16
ILLUSION H30
SKYDOME H16
SKYDOME H30
LULLABY DUCT-OUT VERS.



KIT0167743
Long life filter kit with filters that
can be regenerated for:
CLOUD SEVEN DUCT-OUT
VERS.
HILIGHT-X H16
HILIGHT-GLS H16
HILIGHT-X H30
HILIGHT-GLS H30
ILLUSION H16
ILLUSION H30
SKYDOME H16
SKYDOME H30



KIT0168749
Replacement filter for:
KIT0148450A



KIT0168748
Replacement filter for:
KIT0167743

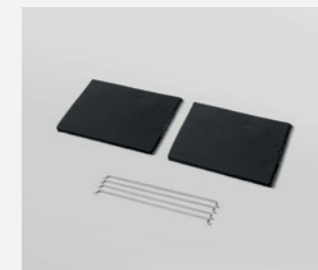

CFC0140426
Regeneratable filter for:
CLOUD SEVEN FILTERING
VERSION



KIT0147861A
Ceramic filter for:
LULLABY FILTERING VERSION



SUSPENDED



INTERSTELLAR

DESIGN FABRIZIO CRISÀ



Diameter 67 cm
Re-circulating
Polished stainless steel + clear glass, polished stainless steel + black glass

A sophisticated chandelier hood that takes centre stage, creating a magical atmosphere with glass prisms which reflect and refract light.

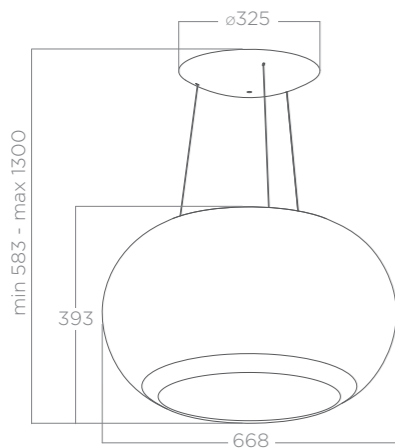

LIGHTING	
Type	LED 9 W
Intensity	261 lux
Temperature	3500 K

SPECIFICATION	
Controls	Touch Control
Speeds	3 speeds + boost
Remote control	✓
Booster airflow	384 m³/h
Noise level	54 dBA
Total power absorption	134 W
Energy class	A
Aluminium grease filter	Included
Revolution filter	Included
Remote control	Included

OPTIONAL ACCESSORIES	
Regeneratable filter	CFC0140090
Extension cable kit (5m)	KIT0112772

MODELS	
INTERSTELLAR Glass	PRF0151808
INTERSTELLAR Black	PRF0151809

PEARL

DESIGN FABRIZIO CRISÀ

Diameter 80 cm
Re-circulating
White pearl, matt white, matt black, polished stainless steel

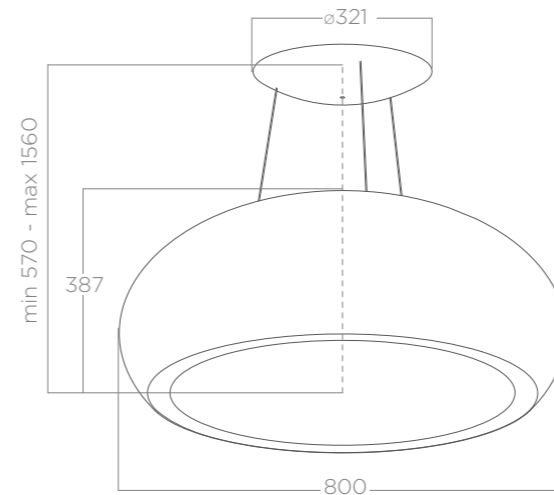

LIGHTING	
Type	NEON 4 x 24 W
Intensity	1386 lux
Temperature	6500 K

SPECIFICATION	
Controls	Remote Control
Speeds	3 speeds + boost
Remote control	✓
Booster airflow	400 m³/h
Noise level	67 dBA
Total power absorption	288 W
Aluminium grease filter	Included
Regeneratable filter	Included
Remote control	Included

OPTIONAL ACCESSORIES	
Extension cable kit (2,5m)	KIT0067590

MODELS	
PEARL White	PRF0024262A
PEARL White matt	PRF0098392
PEARL Black	PRF0098393
PEARL Stainless steel	PRF0098394



DIVA ROCK
Stainless steel ceiling cover,
chromed bracket



DIVA HEAVYMETAL
Stainless steel ceiling cover,
black bracket



DIVA CLASSIC
White ceiling cover, chromed bracket



BELLE ROCK
Stainless steel ceiling cover, chromed bracket



BELLE CLASSIC
White ceiling cover, chromed bracket

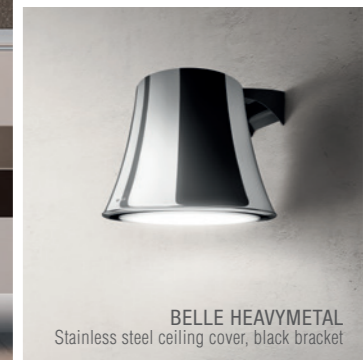

BELLE HEAVYMETAL
Stainless steel ceiling cover, black bracket

DIVA

DESIGN FABRIZIO CRISÀ



Diameter 50 cm
Re-circulating
Coloured metal, polished stainless steel

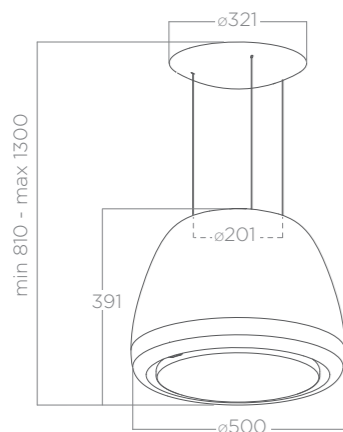

LIGHTING

Type	LED 9 W
Intensity	469 lux
Temperature	3500 K

SPECIFICATION

Controls	Touch Control
Speeds	3 speeds + boost
Remote control	✓
Booster airflow	380 m³/h
Noise level	53 dBA
Total power absorption	54 W
Energy class	A
Aluminium grease filter	Included
Revolution filter	Included
Remote Control	Included

OPTIONAL ACCESSORIES

Regeneratable filter	CFC0140090
Black wall mounted kit	KIT0146155
Chrome wall mounted kit	KIT0146156
Extension cable kit (5m)	KIT0112772

MODELS

DIVA Classic	PRF0098360
DIVA Rock	PRF0098361
DIVA Heavy metal	PRF0098364

BELLE

DESIGN FABRIZIO CRISÀ

Diameter 50 cm
Re-circulating
Coloured metal, polished stainless steel

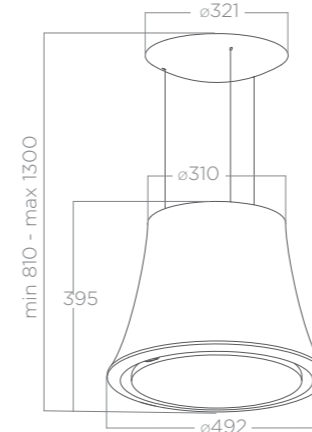

LIGHTING

Type	LED 9 W
Intensity	253 lux
Temperature	3500 K

SPECIFICATION

Controls	Touch Control
Speeds	3 speeds + boost
Remote control	✓
Booster airflow	400 m³/h
Noise level	53 dBA
Total power absorption	54 W
Energy class	A
Aluminium grease filter	Included
Revolution filter	Included
Remote control	Included

OPTIONAL ACCESSORIES

Regeneratable filter	CFC0140090
Black wall mounted kit	KIT0146155
Chrome wall mounted kit	KIT0146156
Extension cable kit (5m)	KIT0112772

MODELS

BELLE Classic	PRF0098365
BELLE Rock	PRF0098366
BELLE Heavy Metal	PRF0098368



CELESTIAL

ELICA DESIGN CENTER

Diameter 47 cm
Re-circulating
Stainless steel + glass

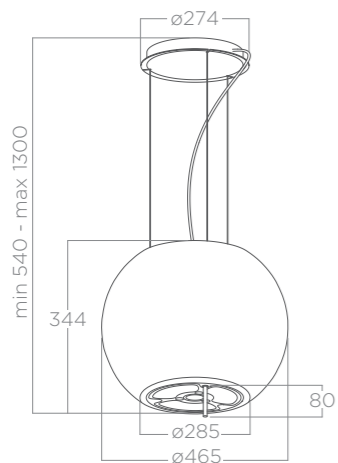

LIGHTING

Type	LED 1x5 W + LED 3x3 W
Intensity	128 lux
Temperature	3000 K

SPECIFICATION

Controls	Magic Wand
Speeds	3 speeds + boost
Booster airflow	515 m ³ /h
Noise level	66 dBA
Total power absorption	234 W
Energy class	B
Aluminium grease filter	Included
Regeneratable filter	Included
Remote control	Included

OPTIONAL ACCESSORIES

White remote control	KIT0121468
Black remote control	KIT0121469
Extension cable kit (2,5m)	KIT01889
Extension cable kit (5m)	KIT01921

MODELS

CELESTIAL	65414592A
-----------	-----------

PIX

DESIGN FABRIZIO CRISÀ



42x42 cm
Re-circulating
White, black, concrete finish, denim finish

Ceiling hood with a signature geometric design featuring cast iron grilles. Available in the classic finishes of black and white or in the latest finishes, such as cement and denim.

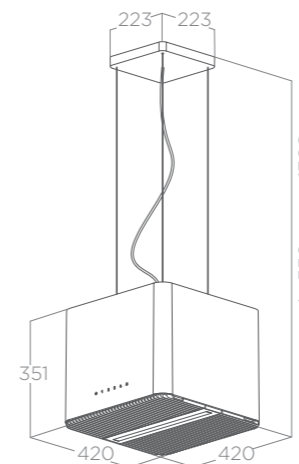
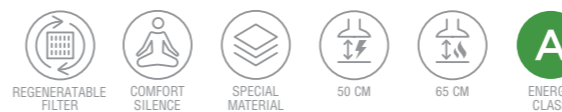

LIGHTING

Type	Strip LED 1 x 7 W
Intensity	365 lux
Temperature	3500 K

SPECIFICATION

Controls	Touch Control
Speeds	3 speeds + boost
Booster airflow	610 m ³ /h
Noise level	60 dBA
Total power absorption	207 W
Energy class	A
Aluminium grease filter	Included
Regeneratable filter	Included

OPTIONAL ACCESSORIES

Wall mounted kit	KIT0146153
Extension cable kit (2,5m)	KIT0147941
Extension cable kit (5m)	KIT0147942

MODELS

PIX White	PRF0145561
PIX Black	PRF0146220
PIX Denim	PRF0146221
PIX Concrete effect	PRF0146222

IKONA LIGHT

DESIGN FABRIZIO CRISÀ





EASY

ELICA DESIGN CENTER



Diameter 52 cm
Re-circulating
Stainless steel, black, white

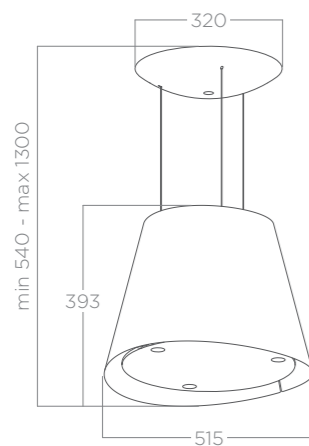
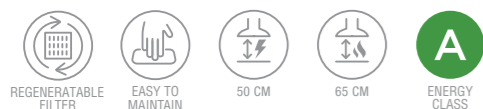

LIGHTING

Type	LED 3 x 2,5 W
Intensity	451 lux
Temperature	4000 K

SPECIFICATION

Controls	Touch Control
Speeds	3 speeds + boost
Booster airflow	610 m³/h
Noise level	62 dBA
Total power absorption	207 W
Energy class	A
Aluminium grease filter	Included
Regeneratable filter	Included

OPTIONAL ACCESSORIES

Wall mounted kit	KIT0121394
Extension cable kit (2,5m)	KIT01889
Extension cable kit (5m)	KIT01921

MODELS

EASY White	PRF0119940A
EASY Black	PRF0120352A
EASY Stainless steel	PRF0120354A

IKONA LIGHT

DESIGN FABRIZIO CRISA

60 cm
Re-circulating
Stainless steel, black soft touch effect, white

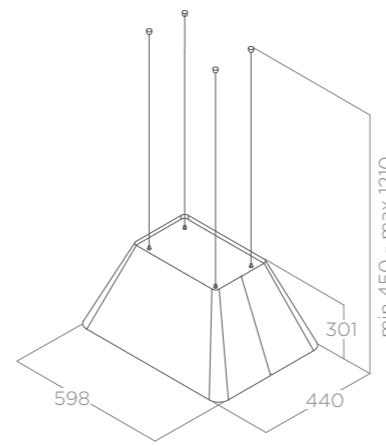

LIGHTING

Type	Strip LED 1x7 W
Intensity	421 lux
Temperature	3500 K

SPECIFICATION

Controls	Touch Control
Speeds	3 speeds + boost
Booster airflow	605 m³/h
Noise level	62 dBA
Total power absorption	267 W
Energy class	A
Aluminium grease filter	Included
Charcoal filter	Included

OPTIONAL ACCESSORIES

Wall mounted kit	KIT0165077
Regeneratable filter	CFC0162221
Extension cable kit (2,5m)	KIT0147941
Extension cable kit (5m)	KIT0147942

MODELS

IKONA LIGHT Stainless steel	PRF0165071
IKONA LIGHT Black	PRF0165082
IKONA LIGHT White	PRF0165083

Possibility for wall mounting by ordering the ancillary installation kit.



SUMMILUX

DESIGN FABRIZIO CRISA



Diameter 50 cm
Re-circulating
Glass + chromed metal

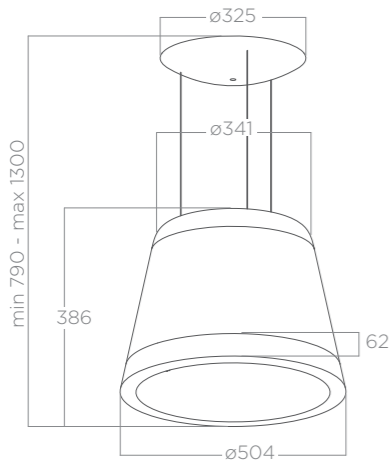

LIGHTING

Type LED 9 W
Intensity 261 lux
Temperature 3500 K

SPECIFICATION

Controls Touch Control
Speeds 3 speeds + boost
Remote control ✓
Booster airflow 384 m³/h
Noise level 53 dBA
Total power absorption 124 W
Energy class A
Aluminium grease filter Included
Revolution filter Included

OPTIONAL ACCESSORIES

Regeneratable filter CFC0140090
Chrome wall mounted kit KIT0146156
Extension cable kit (5m) KIT0112772

MODELS

SUMMILUX Stainless steel PRF0151810

SHINING

DESIGN FABRIZIO CRISA

Diameter 50 cm
Re-circulating
Peltrox effect metal, rust, cast iron

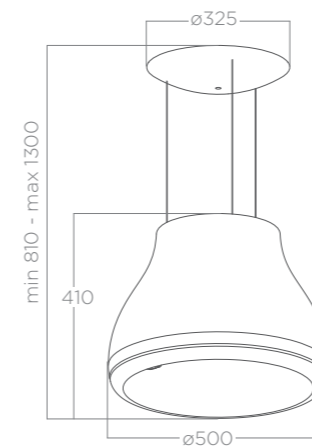

LIGHTING

Type LED 9 W
Intensity 541 lux
Temperature 3500 K

SPECIFICATION

Controls Touch Control
Remote control ✓
Booster airflow 380 m³/h
Noise level 53 dBA
Total power absorption 54 W
Energy class A
Aluminium grease filter Included
Revolution filter Included

OPTIONAL ACCESSORIES

Regeneratable filter CFC0140090
Black wall mounted kit KIT0146155
Chrome wall mounted kit KIT0146156
Extension cable kit (5m) KIT0112772

MODELS

SHINING Peltrox PRF0120497A
SHINING Rust PRF0120528A
SHINING Iron PRF0120590A

Possibility for wall mounting by ordering the ancillary installation kit.

Possibility for wall mounting by ordering the ancillary installation kit.



FLOW

ELICA DESIGN CENTER



Diameter 51 cm
Re-circulating
Stainless steel, black

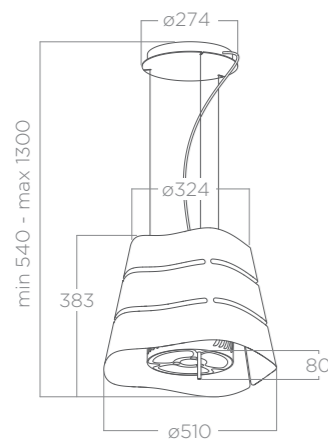

LIGHTING

Type	LED 1x5 W + LED 3x3 W
Intensity	381 lux (Black) 128 lux (Stainless steel)
Temperature	3000 K

SPECIFICATION

Controls	Magic Wand
Speeds	3 speeds + boost
Booster airflow	515 m ³ /h
Noise level	66 dBA
Total power absorption	234 W
Energy class	B
Aluminium grease filter	Included
Regeneratable filter	Included
Ceiling fitting	Included
Wall fitting	Included

OPTIONAL ACCESSORIES

White remote control	KIT0121468
Black remote control	KIT0121469
Extension cable kit (2,5m)	KIT01889
Extension cable kit (5m)	KIT01921

MODELS

FLOW Stainless steel	65414588A
FLOW Black	PRF0090419B

TANDEM

ELICA DESIGN CENTER



90x50 cm
Re-circulating
Stainless steel

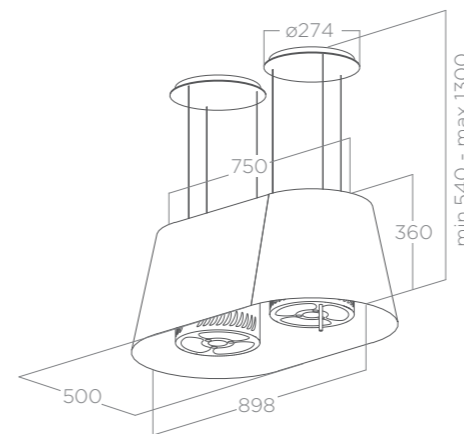

LIGHTING

Type	LED 2 x 5 W
Intensity	350 lux
Temperature	3000 K

SPECIFICATION

Controls	Magic Wand
Speeds	3 speeds + boost
Booster airflow	865 m ³ /h
Noise level	73 dBA
Total power absorption	288 W
Aluminium grease filter	Included
Regeneratable filter	Included

OPTIONAL ACCESSORIES

White remote control	KIT0121468
Black remote control	KIT0121469
Extension cable kit (2,5m)	KIT01889*
Extension cable kit (5m)	KIT01921*

(* to order 2 pcs)

MODELS

TANDEM	65414590A
--------	-----------

Mounting options: both ceiling and wall. Cables and brackets are included in the package.



CAST IRON EFFECT

ZINC COATING EFFECT

JUNO

ELICA DESIGN CENTER



Diameter 50 cm
Re-circulating
Stainless steel, white, black

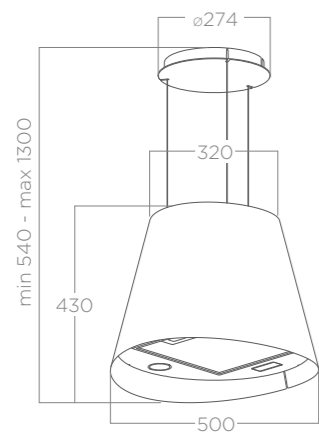
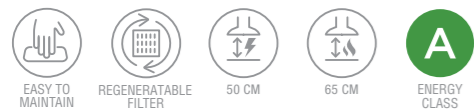

LIGHTING	
Type	LED 2 X 2,5 W
Intensity	381 lux
Temperature	3500 K

SPECIFICATION	
Controls	Soft light push button
Speeds	3 speeds
Max airflow	610 m ³ /h
Noise level	67 dBA
Total power absorption	205 W
Energy class	A
Aluminium grease filter	Included
Regeneratable filter	Included

OPTIONAL ACCESSORIES	
Wall mounted kit	KIT02263
Extension cable kit (2,5m)	KIT01889
Extension cable kit (5m)	KIT01921

MODELS	
JUNO Black	PRF0071970C
JUNO White	PRF0071972C
JUNO Stainless steel	PRF0089651C

JUNO URBAN

ELICA DESIGN CENTER



Diameter 50 cm
Re-circulating
Cast iron effect, zinc coating effect

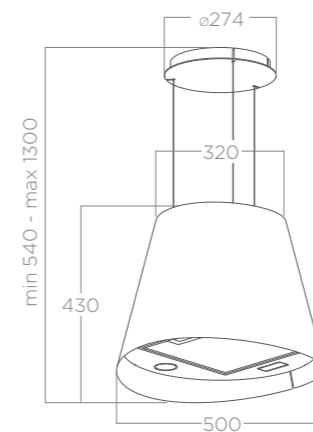
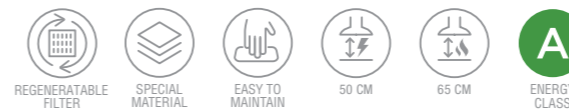

LIGHTING	
Type	LED 2 X 2,5 W
Intensity	381 lux
Temperature	3500 K

SPECIFICATION	
Controls	Soft light push button
Speeds	3 speeds
Max airflow	610 m ³ /h
Noise level	67 dBA
Total power absorption	205 W
Energy class	A
Aluminium grease filter	Included
Regeneratable filter	Included

OPTIONAL ACCESSORIES	
Wall mounted kit	KIT02263
Extension cable kit (2,5m)	KIT01889
Extension cable kit (5m)	KIT01921

MODELS	
JUNO URBAN Cast iron effect	PRF0147728A
JUNO URBAN Zinc coating effect	PRF0147730A



CAST IRON EFFECT

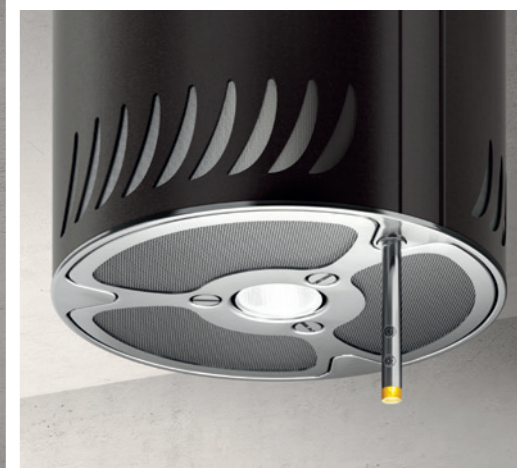

ZINC COATING EFFECT

SIENNA

ELICA DESIGN CENTER



Diameter 25 cm
Re-circulating
Stainless steel



LIGHTING	
Type	LED 1 X 5 W
Intensity	145 lux
Temperature	3000 K

SPECIFICATION	
Controls	Magic wand
Speeds	3 speeds + boost
Booster airflow	515 m ³ /h
Noise level	66 dBA
Total power absorption	225 W
Energy class	B
Aluminium grease filter	Included
Regeneratable filter	Included

OPTIONAL ACCESSORIES	
Extension cable kit (2,5m)	KIT01889
Extension cable kit (5m)	KIT01921
White remote control	KIT0121468
Black remote control	KIT0121469

MODELS	
SIENNA	64714985/1

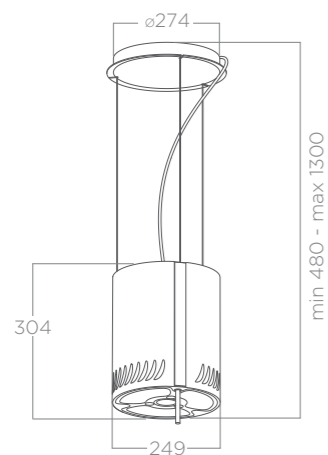

SIENNA URBAN

ELICA DESIGN CENTER



Diameter 25 cm
Re-circulating
Cast iron effect, zinc coating effect

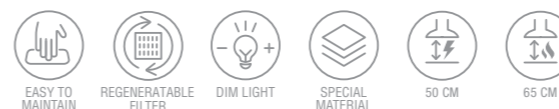

LIGHTING	
Type	LED 1 X 5 W
Intensity	145 lux
Temperature	4000 K

SPECIFICATION	
Controls	Magic wand
Speeds	3 speeds + boost
Booster airflow	515 m ³ /h
Noise level	66 dBA
Total power absorption	225 W
Energy class	B
Aluminium grease filter	Included
Regeneratable filter	Included

OPTIONAL ACCESSORIES	
Extension cable kit (2,5m)	KIT01889
Extension cable kit (5m)	KIT01921
White remote control	KIT0121468
Black remote control	KIT0121469

MODELS	
SIENNA URBAN Cast iron effect	PRF0147733
SIENNA URBAN Zinc coating effect	PRF0147734

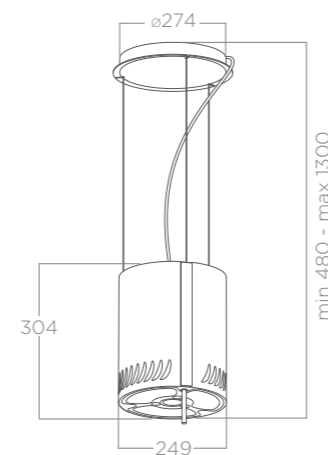

DOWNDRAFT



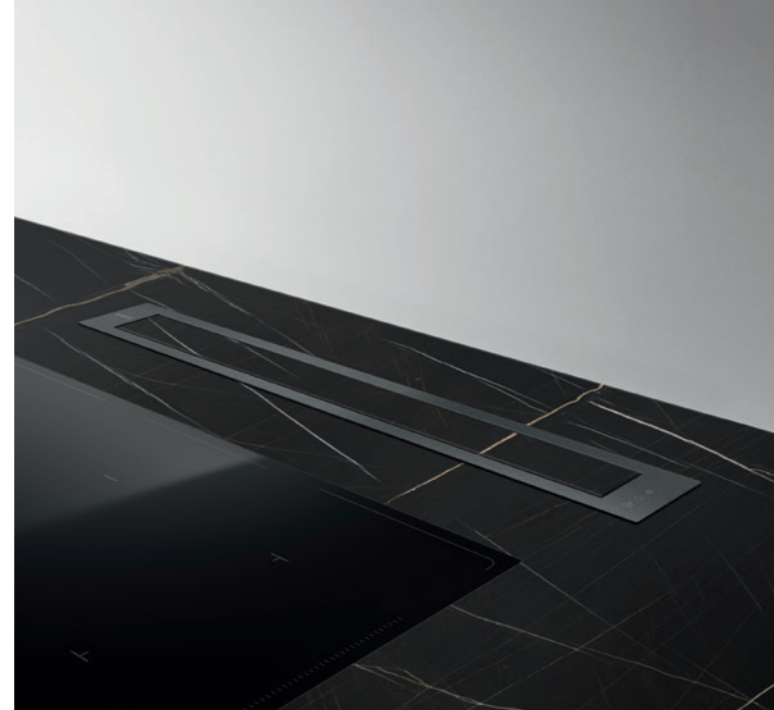

GETUP STAINLESS STEEL

GETUP CAST IRON

GETUP BLACK MATT

GETUP CUSTOMISABLE

GETUP

DESIGN FABRIZIO CRISA

90 cm
 Duct-out/ Re-circulating
 Stainless steel, black soft touch effect + black glass, cast iron effect, cast iron effect + customisable

Can be Wifi connected for control by voice assistant or via the Elica App which even lets you know when the filter needs regenerating.

- EASY TO MAINTAIN
- TOTAL INTEGRATION
- CONNECTIVITY
- HIGH PERFORMANCE REGENERATABLE FILTER
- REGENERATABLE FILTER
- DIM LIGHT
- SPECIAL MATERIAL
- Ø150
- ENERGY CLASS A

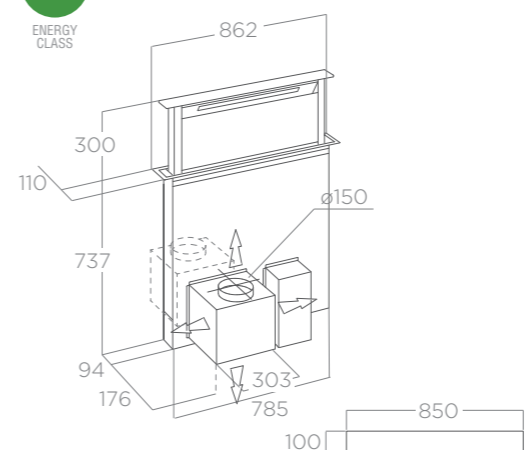

CUT FOR INSTALLATION

LIGHTING

Type	STRIP LED 1x7W
Intensity	203 lux
Temperature	3500 K

SPECIFICATION

Controls	Infrared Touch Control
Speeds	3 speeds + 2 boost levels
Booster airflow	750 m³/h
Noise level	62 dBA
Total power absorption	317 W
Duct size	150 mm
Energy class	A
Aluminium grease filter	Included

OPTIONAL ACCESSORIES

High performance recirculating kit	KIT0166432
Recirculating kit	KIT0166444
Remote motor relocation kit	KIT0166435

MODELS

GETUP Stainless steel	PRF0161680
GETUP Black matt	PRF0162784
GETUP Cast iron	PRF0162866
GETUP Customisable	PRF0162869

TOTAL INSTALLATION FREEDOM

GETUP is designed to be installed discretely into any style of kitchen with the maximum freedom for installation and taking up a minimum amount of space - all thanks to its compact size and the flexibility of positioning the extraction unit.

This flexibility means the motor can be positioned on either side of the unit with the outlet in one of four directions or remotely - up to 3 metres away - which frees up even more space below your hob as well as keeping the noise level where you are working to an absolute minimum.



ORIGINAL FINISHES

Materials have always been one of the fundamental elements for Elica in the innovation process, resulting in statement solutions, in line with latest design trends. We have produced GETUP with 4 finishes.

The peerless black finish is interpreted with a combination of black glass and details in soft touch paint while the classic solution in stainless steel showcases its timeless elegance.

The cast-iron effect is a brand-new addition. Highlighted by a titanium trim, it blends in perfectly with the latest kitchen styles and the aesthetics of gas hobs with their cast iron pan supports and brass burners. The "naked" model allows you to cover the upper panel with any material, even the same one as the worktop, making GETUP really customisable product.

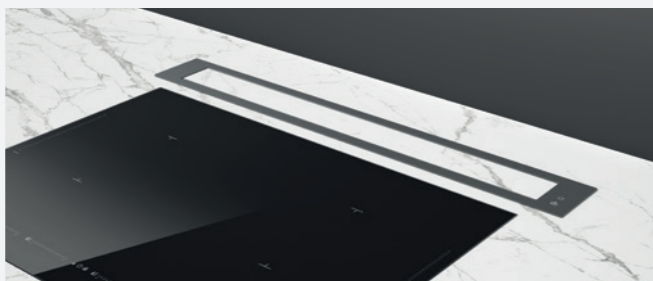
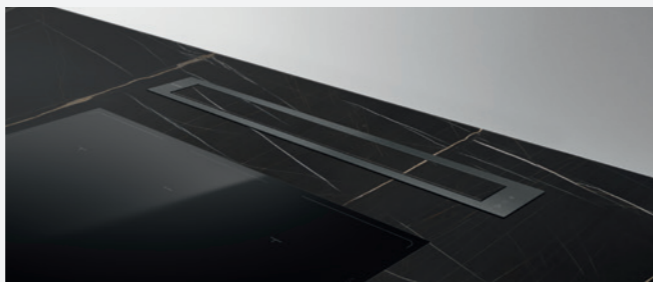

PANDORA

DESIGN FABRIZIO CRISÀ

90 cm
Re-circulating or duct-out (Internal motor models)
Duct-out (remote motor models)
Stainless steel, black



SPECIFICATION

Controls	Touch Control
Speeds	3 speeds + boost
Booster airflow	669 m ³ /h
Noise level	59 dBA
Total power absorption	275 W
Duct size	150 mm
Energy class	A
Aluminium grease filter	Included
Charcoal filter	Included (internal motor models)

OPTIONAL ACCESSORIES

Remote motor GME22 for external installation	PRF0006212A
Remote motor GME88 for internal installation	PRF0046491A

MODELS

PANDORA GME Black	PRF0120981
PANDORA GME Stainless steel	PRF0120982
PANDORA Black (*)	PRF0120979
PANDORA Stainless steel (*)	PRF0120980

For remote motors specification see page 180

STD VERSION

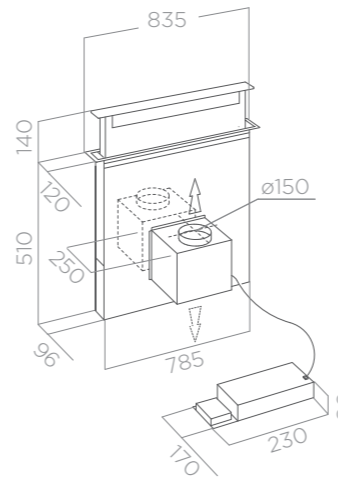

GME VERSION

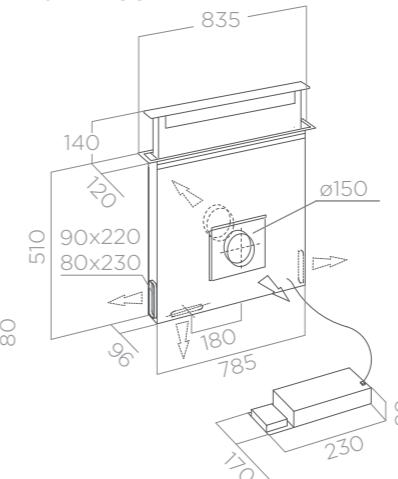

BUILT-IN





COSA MANCA: PANE
BISCOTTI
FRAGOLE
MELANZANE
ZUCCHINE

SLEEK 2.0 @
DESIGN FABRIZIO CRISÀ



SLEEK 2.0 @

DESIGN FABRIZIO CRISA

60 - 80 cm
Duct-out/Re-circulating
Stainless steel, black soft touch effect + black glass

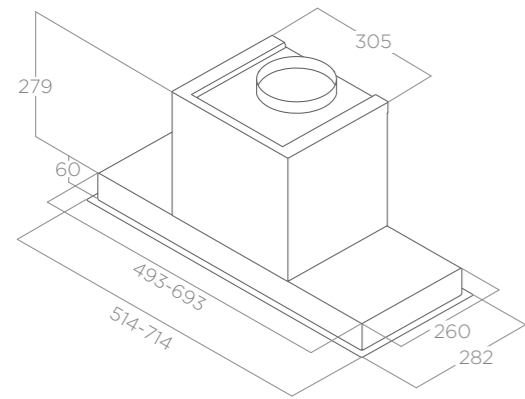
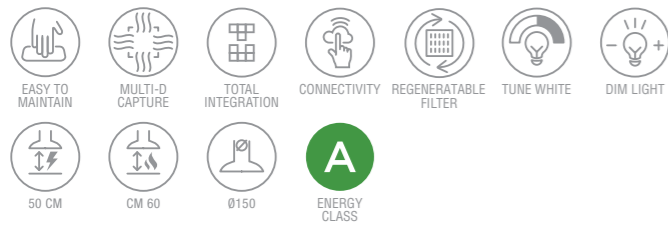

LIGHTING	
Type	STRIP LED 1x7W
Intensity	309 lux
Temperature	2700 - 6500 K

SPECIFICATION	
Controls	Touch Control
Speeds	3 speeds + boost
Booster airflow	700 m³/h
Noise level	67 dBA
Total absorption	280 W
Duct size	150 mm
Energy class	A
Aluminium grease filter	Included

OPTIONAL ACCESSORIES	
Charcoal filter	CFC0140343
Regeneratable filter	CFC0162221
Telescopic chimney kit h18,5+h18,5	KIT0141458

MODELS	
SLEEK 2.0 @ Stainless steel 60	PRF0164340
SLEEK 2.0 @ Stainless steel 80	PRF0164356
SLEEK 2.0 @ Black 60	PRF0164361
SLEEK 2.0 @ Black 80	PRF0164391

SLEEK 2.0

ELICA DESIGN CENTER

60 - 80 cm
Duct-out/Re-circulating
Stainless steel, Stainless steel + white glass

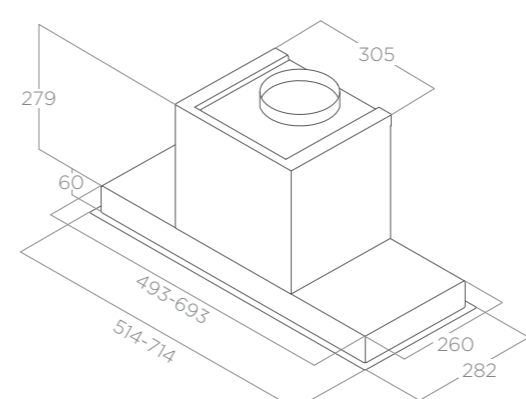

LIGHTING	
Type	Strip LED 1 x 7 W
Intensity	365 lux
Temperature	3500 K

SPECIFICATION	
Controls	Touch Control
Speeds	3 speeds + boost
Booster airflow	690 m³/h
Noise level	67 dBA
Total power absorption	267 W
Duct size	150 mm
Energy class	A
Aluminium grease filter	Included

OPTIONAL ACCESSORIES	
Charcoal filter	CFC0140343
Regeneratable filter	CFC0162221
Telescopic chimney kit h18,5+h18,5	KIT0141458

MODELS	
SLEEK 60 Stainless steel	PRF0092333A
SLEEK 80 Stainless steel	PRF0095073A
SLEEK 60 White	PRF0097676A
SLEEK 80 White	PRF0097708A

Can be Wifi connected for control by voice assistant or via the Elica App.



ERA HE

ELICA DESIGN CENTER

60 - 80 cm
Duct-out/Re-circulating
Stainless steel

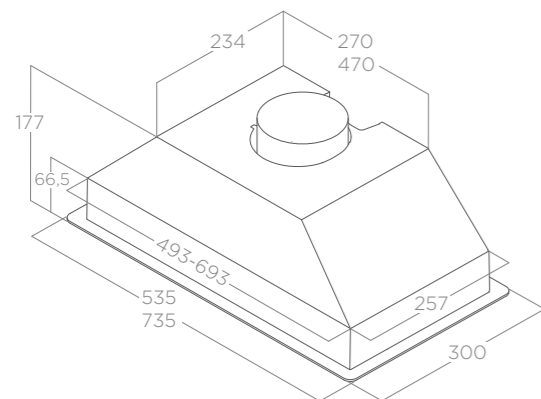
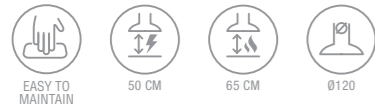

LIGHTING

Type	LED 2 x 3 W
Intensity	73 lux
Temperature	2700 K

SPECIFICATION

Controls	Rotative
Speeds	3 speeds
Max airflow	428 m³/h
Noise level	68 dBA
Total power absorption	121 W
Duct size	120 mm
Energy class	B
Aluminium grease filter	Included

OPTIONAL ACCESSORIES

Charcoal filter	CFC0141571
-----------------	------------

MODELS

ERA HE 60 Stainless steel	PRF0142886
ERA HE 80 Stainless steel	PRF0142744

ERA LUX

ELICA DESIGN CENTER

60 - 80 cm
Duct-out/Re-circulating
Stainless steel, white, black

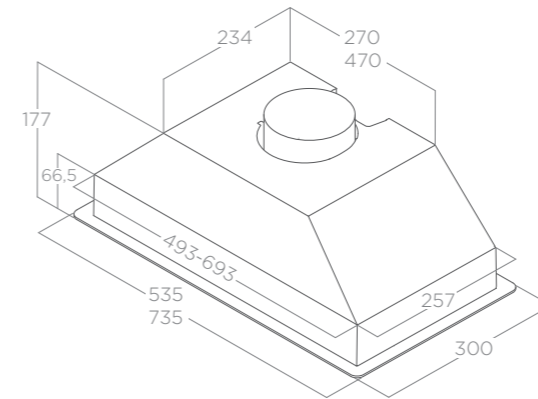
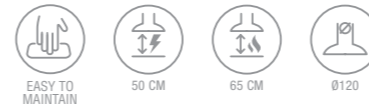

LIGHTING

Type	LED 2 x 3 W
Intensity	73 lux
Temperature	2700 K

SPECIFICATION

Controls	Push button
Speeds	3 speeds
Max airflow	368 m³/h
Noise level	67 dBA
Total power absorption	146 W
Duct size	120 mm
Energy class	D
Aluminium grease filter	Included

OPTIONAL ACCESSORIES

Charcoal filter	CFC0141571
-----------------	------------

MODELS

ERA LUX 60 White	PRF0142716
ERA LUX 60 Stainless steel	PRF0142723
ERA LUX 60 Black	PRF0166822
ERA LUX 80 White	PRF0142728
ERA LUX 80 Stainless steel	PRF0142741
ERA LUX 80 Black	PRF0166823



ERA STD

ELICA DESIGN CENTER

60 - 80 cm
Duct-out/Re-circulating
Silver

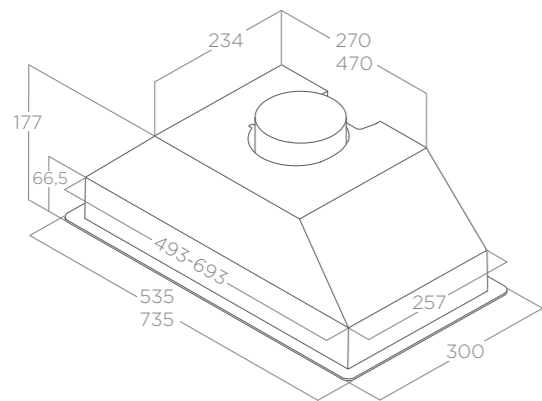
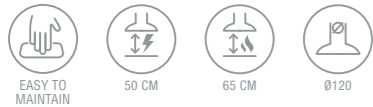

LIGHTING

Type	LED 2 x 3 W
Intensity	78 lux
Temperature	2700 K

SPECIFICATION

Controls	Slider
Speeds	3 speeds
Max airflow	224 m ³ /h
Noise level	54 dBA
Total power absorption	81 W
Duct size	120 mm
Energy class	C
Aluminium grease filter	Included

OPTIONAL ACCESSORIES

Charcoal filter	CFC0141571
-----------------	------------

MODELS

ERA STD 60	PRF0142633
ERA STD 80	PRF0142701

LANE

DESIGN FABRIZIO CRISA

60 - 80 cm
Duct-out/Re-circulating
Stainless steel, black soft touch effect, white

A high performance hood that blends perfectly with minimalist design and offers excellent value for money. The patented installation system allows the hood to be secured to the cabinet with only 2 screws from below, in less than one minute. Remote motor versions for in-line or external installation.

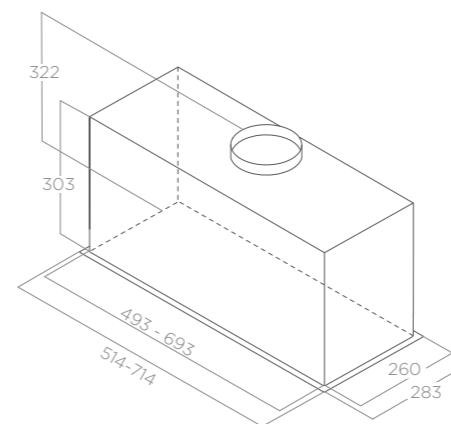

LIGHTING

Type	Strip led 1x7W
Intensity	365 LUX
Temperature	3500 K

SPECIFICATION*

Controls	Electronic push button
Speeds	3 speeds + boost
Booster airflow	650 m ³ /h
Noise level	65 dBA
Total power absorption	257 W
Duct size	150 mm
Energy class	B
Aluminium grease filter	Included

* models with interior motor. For remote motor performance see page 180

OPTIONAL ACCESSORIES

Charcoal filter	CFC0140343
Regeneratable filter	CFC0162221

MODELS

LANE 60 Stainless steel	PRF0157333
LANE 60 White	PRF0157357
LANE 60 Black	PRF0165830
LANE 60 Stainless steel remote†	PRF0171141
LANE 80 Stainless steel	PRF0157377
LANE 80 White	PRF0157394
LANE 80 Black	PRF0165834
LANE 80 Stainless steel remote†	PRF0171142

† For GME 01 external and GME ELICA in-line remote motors see page 180

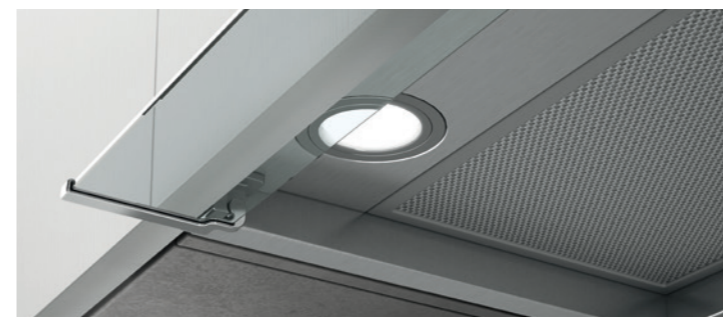

BOXIN NO DRIP

ELICA DESIGN CENTER

60 - 90 - 120 cm
Duct-out/Re-circulating
Stainless steel
Solves the problem of condensation with mechanical and electrical systems able to guarantee an all-round solution. The system has been designed to prevent dripping on the hob, as well as protect wall units from steam.

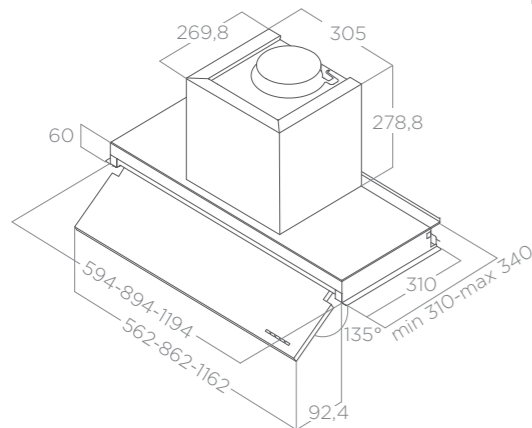
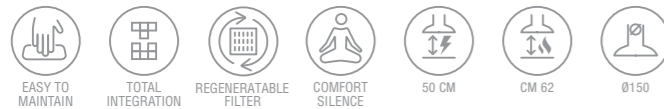

LIGHTING

Type	LED 2x2,5W
Intensity	381 lux
Temperature	3500 K

SPECIFICATION

Controls	Electronic push button
Speeds	3 speeds + boost
Booster airflow	560 m³/h
Noise level	60 dBA
Total power absorption	300 W
Duct size	150mm
Energy class	A
Aluminium grease filter	Included

OPTIONAL ACCESSORIES

Charcoal filter	CFC0140343
Regeneratable filter	CFC0162221
Chimney kit H12	KIT0091876
Chimney kit H18,5+18,5	KIT0141458

MODELS

BOXIN NO DRIP 60 Stainless steel	PRF0157712
BOXIN NO DRIP 90 Stainless steel	PRF0156613
BOXIN NO DRIP 120 Stainless steel	PRF0157280

BOXIN HE - BOXIN LUX - BOXIN

ELICA DESIGN CENTER

60 - 90 - 120 cm
Duct-out/Re-circulating
Stainless steel (BOXIN + BOXIN LUX)
Stainless steel + white glass (BOXIN HE version)

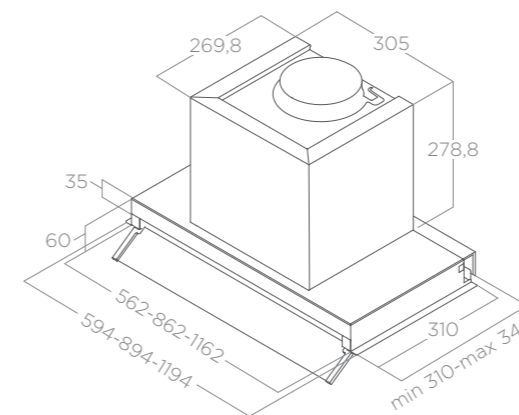

LIGHTING

Type	STD	LUX	HE
Intensity	LED 2 x 2,5 W	LED 2 x 2,5 W	LED 2 x 2,5 W
Temperature	381 lux	381 lux	381 lux
	3500 K	3500 K	3500 K

SPECIFICATION

	STD	LUX	HE
Controls	Rotative	Rotative	Rotative
Speeds	3 speeds	3 speeds	3 speeds
Max airflow	370 m³/h	620 m³/h	610 m³/h
Noise level	67 dBA	70 dBA	70 dBA
Total power absorption	95 W	255 W	255 W
Duct size	150 mm	150 mm	150 mm
Energy class	D	A	B
Aluminium grease filter	Included	Included	Included
Perimeter aspiration			✓

OPTIONAL ACCESSORIES

Charcoal filter (HE and LUX)	CFC0140343
Charcoal filter*	CFC0141497
Regeneratable filter (HE and LUX)	CFC0162221
Chimney kit H12	KIT0091876
Telescopic Chimney kit H18+H18	KIT0141458

MODELS

BOXIN 60 Stainless steel (*)	PRF0097835B
BOXIN 90 Stainless steel (*)	PRF0097839B
BOXIN 120 Stainless steel (*)	PRF0097842B
BOXIN LUX 60 Stainless steel	PRF0114760A
BOXIN LUX 90 Stainless steel	PRF0114761A
BOXIN LUX 120 Stainless steel	PRF0114762A
BOXIN HE 60 Stainless steel + White glass	PRF0097795A
BOXIN HE 90 Stainless steel + White glass	PRF0097796A
BOXIN HE 120 Stainless steel + White glass	PRF0097797A



GLASS OUT

DESIGN FABRIZIO CRISA

60 - 90 cm
Duct-out/Re-circulating
Stainless steel + glass

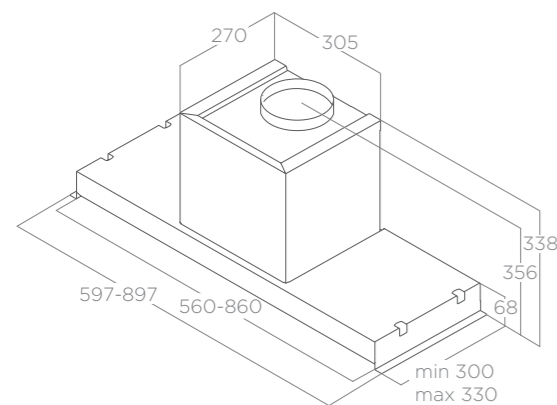
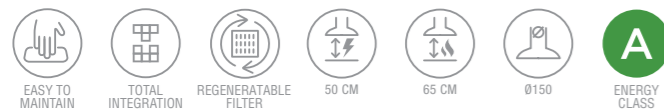

LIGHTING

Type	Strip LED 1 x 7 W
Intensity	147 lux
Temperature	4000 K

SPECIFICATION

Controls	Push button
Speeds	3 speeds + boost
Booster airflow	560 m³/h
Noise level	61 dBA
Total power absorption	227 W
Duct size	150 mm
Energy class	A
Aluminium grease filter	Included

OPTIONAL ACCESSORIES

Charcoal filter	CFC0140343
Regeneratable filter	CFC0162221
Chimney kit H12	KIT0091876
Telescopic chimney kit h18,5+h18,5	KIT0141458

MODELS

GLASS OUT 60	PRF0109787
GLASS OUT 90	PRF0109788

HIDDEN

ELICA DESIGN CENTER

60 - 90 - 120 cm
Duct-out/Re-circulating
Stainless steel + white glass

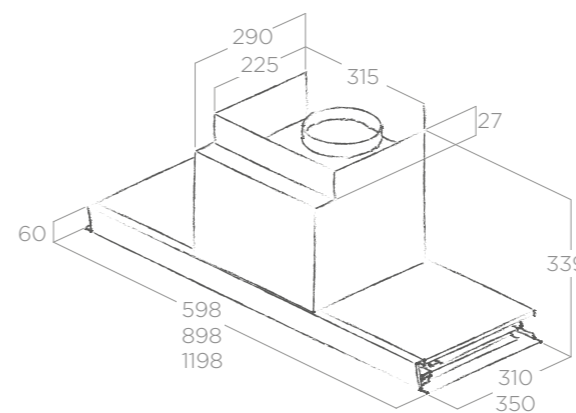
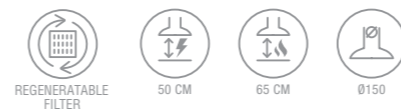

LIGHTING

Type	LED 2x2,5 W
Intensity	181 (60cm) 145 (90-120cm) lux
Temperature	4000 K

SPECIFICATION

Controls	Rotative
Speeds	3 speeds + boost
Booster airflow	570 m³/h
Noise level	64 dBA
Total power absorption	255 W
Duct size	150 mm
Energy class	D
Aluminium grease filter	Included

OPTIONAL ACCESSORIES

Regeneratable filter	CFC0140394
----------------------	------------

MODELS

HIDDEN 60	PRF0025026
HIDDEN 90	PRF0025028
HIDDEN 120	PRF0025030



ELIBLOC HT



ELIBLOC LUX



ELIBLOC

ELICA DESIGN CENTER

60 - 80 cm
Duct-out/Re-circulating
Silver, stainless steel, black

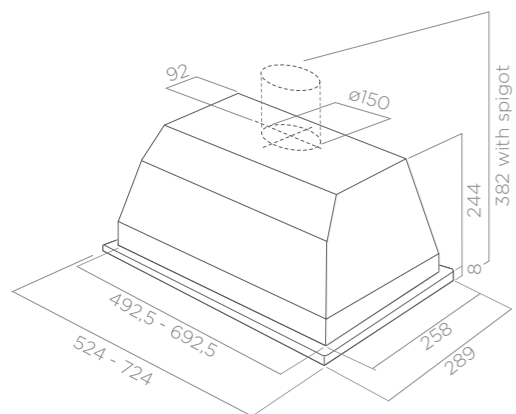

LIGHTING

Type	LED 2x5 W
Intensity	761 lux
Temperature	3000 K

SPECIFICATION

	HT	LUX
Controls	Slider	Electronic push button
Speeds	4 speeds	3 speeds + boost
Max airflow	645 m ³ /h	690 m ³ /h
Noise level	71 dBA	70 dBA
Total power absorption	210 W	285 W
Duct size	150	150
Energy class	C	C
Aluminium grease filter	Included	Included

OPTIONAL ACCESSORIES

Charcoal filter	CFC0140122
-----------------	------------

MODELS

ELIBLOC HT 60 Silver	1768336A
ELIBLOC HT 80 Silver	17614580A
ELIBLOC LUX 60 Stainless steel	PRF0165627
ELIBLOC LUX 60 Black	PRF0165624
ELIBLOC LUX 80 Stainless steel	PRF0165628
ELIBLOC LUX 80 Black	PRF0165626

KREA

ELICA DESIGN CENTER

60 - 90 cm
Duct-out/Re-circulating
Stainless steel, white, black

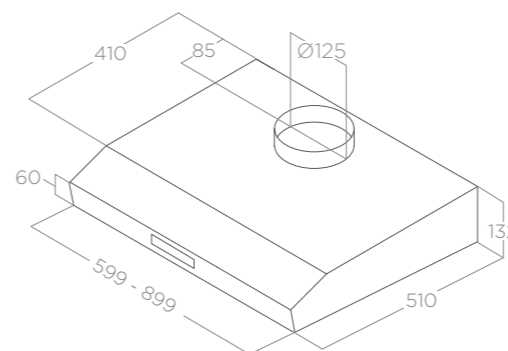

LIGHTING

	STD	LUX
Type	LED 2 x 3 W	LED 2 x 3 W
Intensity	97 lux	97 lux
Temperature	2700 K	2700 K

SPECIFICATION

	STD	LUX
Controls	Slider	Slider
Speeds	3 speeds	3 speeds
Max airflow	272 m ³ /h	335 m ³ /h
Noise level	71 dBA	73 dBA
Total power absorption	121 W	166 W
Duct size	120 mm	120 mm
Energy class	D	D
Aluminium grease filter	Included	Included
Charcoal filter	Included	Included

MODELS

KREA STD 60 Black	PRF0012484D
KREA STD 60 Stainless steel	PRF0012488D
KREA STD 60 White	PRF0012495D
KREA LUX 60 Stainless steel	PRF0012551B
KREA LUX 90 Stainless steel	PRF0012543B



INTEGRATA

ELICA DESIGN CENTER

60 cm
Duct-out/Re-circulating
Silver

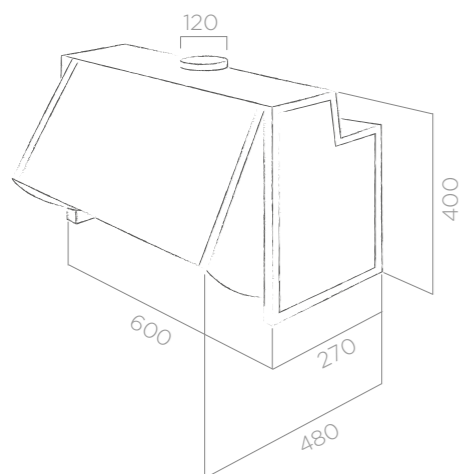

LIGHTING	
Type	LED 2 x 3 W
Intensity	169 lux
Temperature	2700 K

SPECIFICATION	
Controls	Slider
Speeds	3 speeds
Max airflow	288 m ³ /h
Noise level	67 dBA
Total power absorption	121 W
Duct size	120 mm
Energy class	D
Aluminium grease filter	Included

OPTIONAL ACCESSORIES	
Charcoal filter	F00428

MODELS	
INT LED SP	5414464C



LEVER

DESIGN FABRIZIO CRISÀ

60 - 90 - 120 cm
Duct-out/Re-circulating
Stainless steel + glass

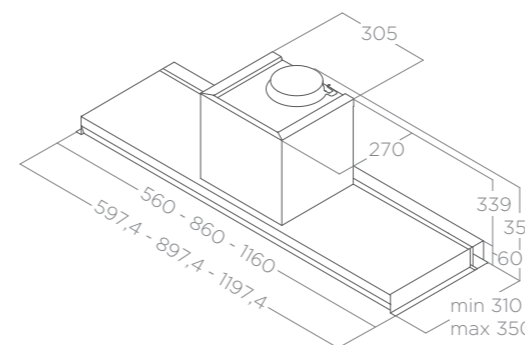

LIGHTING	
Type	LED 2 x 2,5 W
Intensity	145 lux
Temperature	3500 K

SPECIFICATION	
Controls	Push button
Speeds	3 speeds
Max airflow	603 m ³ /h
Noise level	67 dBA
Total power absorption	255 W
Duct size	150 mm
Energy class	B
Aluminium grease filter	Included

OPTIONAL ACCESSORIES	
Charcoal filter	CFC0140343
Regeneratable filter	CFC0162221
Chimney kit H12	KIT0091876
Chimney kit H18,5+18,5	KIT0141458

MODELS	
LEVER 60 Stainless steel	PRF0160153
LEVER 90 Stainless steel	PRF0160152
LEVER 120 Stainless steel	PRF0163362



SKLOCK

ELICA DESIGN CENTER

60 - 90 cm
Duct-out/Re-circulating
Silver

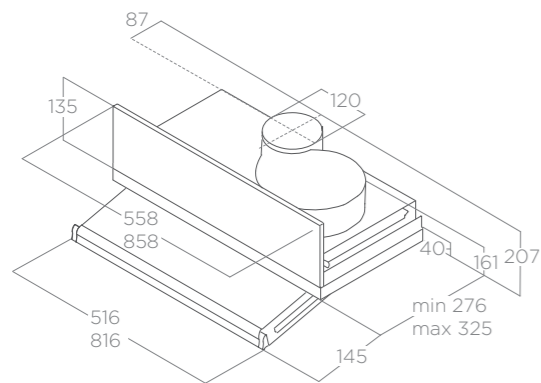
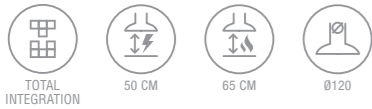

LIGHTING	
Type	LED 2 x 2,5 W
Intensity	141 lux
Temperature	3000 K

SPECIFICATION	
Controls	Slider
Speeds	3 speeds
Max airflow	255 m³/h
Noise level	66 dBA
Total power absorption	120 W
Duct size	120 mm
Energy class	D
Aluminium grease filter	Included

OPTIONAL ACCESSORIES	
Charcoal filter	CFC0141563

MODELS	
SKLOCK 60	PRF0160730
SKLOCK 90	PRF0160733



ELITE 35

ELICA DESIGN CENTER

60 - 90 cm
Duct-out/Re-circulating
Silver + stainless steel

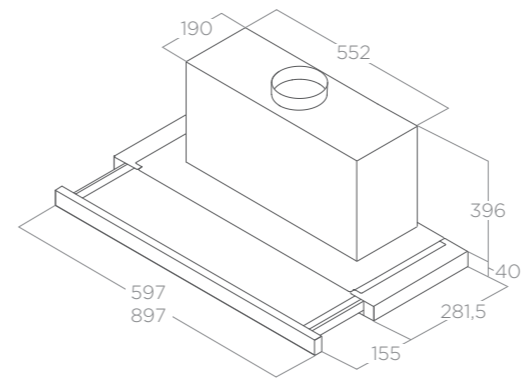
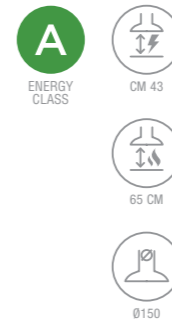

LIGHTING	
Type	LED 2 x 3 W
Intensity	49 lux
Temperature	2700 K

SPECIFICATION	
Controls	Push button
Speeds	3 speeds + boost
Booster airflow	640 m³/h
Noise level	63 dBA
Total power absorption	206 W
Duct size	150 mm
Energy class	A
Aluminium grease filter	Included

OPTIONAL ACCESSORIES	
Charcoal filter	CFC0140075

MODELS	
ELITE 35 90	PRF0139069
ELITE 35 60	PRF0139077



ELITE 14

ELICA DESIGN CENTER

60 - 90 cm
Duct-out/Re-circulating
Silver + stainless steel

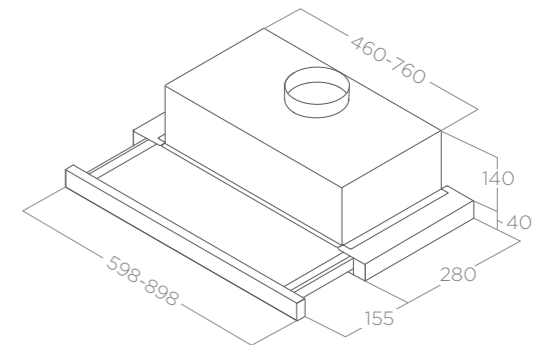

LIGHTING	
Type	LED 2 x 3 W
Intensity	73 lux
Temperature	2700 K

SPECIFICATION	
Controls	Mechanical push button
Speeds	3 speeds
Max airflow	304 m³/h
Noise level	62 dBA
Total power absorption	121 W
Duct size	120 mm
Energy class	D
Aluminium grease filter	Included

OPTIONAL ACCESSORIES	
Charcoal filter	CFC0141571

MODELS	
ELITE 14 LED 60	PRF0037989B
ELITE 14 LED 90	PRF0037992B



GLIDE

ELICA DESIGN CENTER

60 - 90 cm
Duct-out/Re-circulating
Stainless steel + glass



LONG LIFE
FILTER



43 cm



65 cm

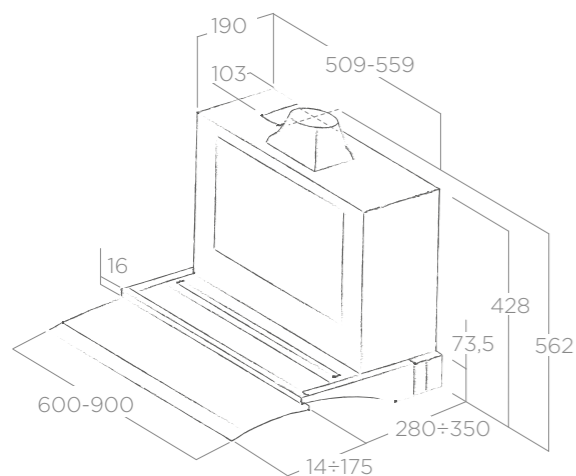

LIGHTING

Type	LED 2 x 3 W
Intensity	457 lux
Temperature	2700 K

SPECIFICATION

Controls	Soft light
Speeds	3 speeds
Max airflow	610 m ³ /h
Noise level	68 dBA
Total power absorption	206 W
Duct size	150 mm
Energy class	B
Aluminium grease filter	Included

OPTIONAL ACCESSORIES

Regeneratable filter	CFC0149389
----------------------	------------

MODELS

GLIDE LED 60	52614597C
GLIDE LED 90	52614598C

GOOD TO KNOW

For those of you, who like to keep up with the latest trends and are not just looking for an attractive finish, but also want detailed information about functionality, we have created a section in which you can source all the details on accessories, useful information, advice on how to choose your hood, warranties and energy labels.

LEARN MORE ABOUT WEIGHT

In kitchen designs featuring an island, suspended or ceiling hood (built into a false ceiling), it is important that the plasterboard structure is able to support the weight of the hood itself.

The weight varies depending on the model and overall dimensions, and the following table is a useful aid in developing a suitable support without needing to forgo a practical and stylish open space.

	WEIGHT		WEIGHT
ADÉLE ISLAND	27,4 Kg	JUNO	13,40 Kg
BELLE	18,85 Kg	JUNO URBAN	13,50 Kg
BIO ISLAND	32,80 Kg	LULLABY (DUCT-OUT)	42,00 Kg
CELESTIAL	16,70 Kg	LULLABY (FILTERING)	50,00 Kg
CLOUD SEVEN (DUCT-OUT)	17,70 Kg	METEORITE ISLAND	40,40 Kg
CLOUD SEVEN (FILTERING)	19,50 Kg	PIX	16,40 Kg
DIVA	19,25 Kg	PEARL	33,80 Kg
EASY	11,65 Kg	REEF A ISLAND	26,20 Kg
FLOW	14,50 Kg	SIENNA	8,30 Kg
GALAXY ISLAND	24,50 Kg	SIENNA URBAN	7,50 Kg
HAIKU ISLAND (32 cm)	33,70 Kg	SHINING	19,00 Kg
HAIKU ISLAND (120 cm)	46,30 Kg	SKYDOME (H16)	25,20 Kg
HAIKU ISLAND (180 cm)	55,10 Kg	SKYDOME (H30)	27,20 Kg
HILIGHT-GLS / HILIGHT-X (H16)	31,00 Kg	SKYDOME (NO MOTOR)	21,70 Kg
HILIGHT-GLS / HILIGHT-X (H30)	34,10 Kg	SUMMILUX	22,20 Kg
HILIGHT-GLS / HILIGHT-X (NO MOTOR)	24,80 Kg	THIN ISLAND	34,20 Kg
IKONA LIGHT	15,00 Kg	TRIBE A ISLAND	28,20 Kg
ILLUSION (H16)	23,00 Kg	TUBE PRO ISLAND	26,35 Kg
ILLUSION (H30)	23,70 Kg	TANDEM	26,40 Kg
ILLUSION (NO MOTOR)	19,50 Kg	YIN	66,00 Kg
INTERSTELLAR	27,10 Kg		

LEARN MORE ABOUT PERFORMANCE

	ENERGY CLASS	1 SPEED (airflow-noise)	2 SPEED (airflow-noise)	3 SPEED (airflow-noise)	4 SPEED * (airflow-noise)	5 SPEED * (airflow-noise)
ACUTA	A	272 m³/h - 46 dBA	368 m³/h - 53 dBA	515 m³/h - 60 dBA	---	625 m³/h - 65 dBA
ADÉLE	A	325 m³/h - 55 dBA	435 m³/h - 61 dBA	630 m³/h - 69 dBA	---	770 m³/h - 74 dBA
ADÉLE ISLAND	A	325 m³/h - 55 dBA	435 m³/h - 61 dBA	630 m³/h - 69 dBA	---	770 m³/h - 74 dBA
ALPHA	A	280 m³/h - 52 dBA	405 m³/h - 60 dBA	540 m³/h - 67 dBA	---	620 m³/h - 70 dBA
APLOMB	A	275 m³/h - 51 dBA	385 m³/h - 59 dBA	495 m³/h - 64 dBA	---	680 m³/h - 71 dBA
AQUAVITAE	D	130 m³/h - 43 dBA	155 m³/h - 50 dBA	320 m³/h - 68 dBA	---	---
ASCENT	B	288 m³/h - 50 dBA	432 m³/h - 58 dBA	603 m³/h - 65 dBA	---	757 m³/h - 69 dBA
ASCENT URBAN	B	288 m³/h - 50 dBA	432 m³/h - 58 dBA	603 m³/h - 65 dBA	---	757 m³/h - 69 dBA
BELLE	A	160 m³/h - 36 dBA	205 m³/h - 41 dBA	335 m³/h - 53 dBA	---	380 m³/h - 56 dBA
BIO	A+	125 m³/h - 32 dBA	410 m³/h - 56 dBA	496 m³/h - 60 dBA	610 m³/h - 65 dBA	757 m³/h - 69 dBA
BIO ISLAND	A+	125 m³/h - 32 dBA	410 m³/h - 56 dBA	496 m³/h - 60 dBA	610 m³/h - 65 dBA	757 m³/h - 69 dBA
BLOOM	A	185 m³/h - 35 dBA	310 m³/h - 52 dBA	400 m³/h - 56 dBA	---	750 m³/h - 70 dBA
BLOOM-S	A	185 m³/h - 35 dBA	310 m³/h - 46 dBA	400 m³/h - 53 dBA	590 m³/h - 58 dBA	750 m³/h - 64 dBA
BOXIN	D	140 m³/h - 48 dBA	190 m³/h - 54 dBA	370 m³/h - 67 dBA	---	---
BOXIN HE	B	230 m³/h - 49 dBA	335 m³/h - 56 dBA	610 m³/h - 70 dBA	---	---
BOXIN LUX	A	255 m³/h - 49 dBA	355 m³/h - 55 dBA	620 m³/h - 67 dBA	---	---
BOXIN NO DRIP	A	105 m³/h - 30 dBA	250 m³/h - 53 dBA	365 m³/h - 60 dBA	---	600 m³/h - 69 dBA
CELESTIAL	B	208 m³/h - 51 dBA	272 m³/h - 59 dBA	384 m³/h - 66 dBA	---	515 m³/h - 72 dBA
CLAIRE	B	272 m³/h - 52 dBA	406 m³/h - 60 dBA	581 m³/h - 69 dBA	713 m³/h - 73 dBA	---
CLOUD SEVEN	A	235 m³/h - 43 dBA	330 m³/h - 54 dBA	460 m³/h - 60 dBA	660 m³/h - 68 dBA	770 m³/h - 71 dBA
CRUISE	B	288 m³/h - 51 dBA	432 m³/h - 61 dBA	581 m³/h - 69 dBA	---	713 m³/h - 73 dBA
DIVA	A	160 m³/h - 36 dBA	205 m³/h - 41 dBA	335 m³/h - 53 dBA	---	380 m³/h - 56 dBA
DOLCE	A	230 m³/h - 46 dBA	335 m³/h - 54 dBA	465 m³/h - 61 dBA	---	580 m³/h - 66 dBA
EASY	A	260 m³/h - 45 dBA	375 m³/h - 55 dBA	520 m³/h - 62 dBA	---	610 m³/h - 67 dBA
ELIBLOC HT	C	256 m³/h - 49 dBA	368 m³/h - 58 dBA	496 m³/h - 65 dBA	647 m³/h - 71 dBA	---
ELIBLOC LUX	C	285 m³/h - 54 dBA	405 m³/h - 63 dBA	560 m³/h - 70 dBA	---	690 m³/h - 74 dBA
ELITE 14	D	125 m³/h - 46 dBA	288 m³/h - 57 dBA	304 m³/h - 62 dBA	---	---
ELITE 35	A	250 m³/h - 46 dBA	375 m³/h - 55 dBA	535 m³/h - 63 dBA	---	640 m³/h - 67 dBA
ERA STD	C	125 m³/h - 45 dBA	155 m³/h - 47 dBA	224 m³/h - 54 dBA	---	---
ERA LUX	D	290 m³/h - 62 dBA	344 m³/h - 66 dBA	368 m³/h - 67 dBA	---	---
ERA HE	B	236 m³/h - 57 dBA	332 m³/h - 63 dBA	428 m³/h - 68 dBA	---	---
FILM	A	240 m³/h - 43 dBA	335 m³/h - 51 dBA	515 m³/h - 62 dBA	---	670 m³/h - 67 dBA
FLOW	B	208 m³/h - 51 dBA	272 m³/h - 59 dBA	384 m³/h - 66 dBA	---	515 m³/h - 72 dBA

* Booster time speeds

** Model not subject to compulsory energy certification.

LEARN MORE ABOUT PERFORMANCE

	ENERGY CLASS	1 SPEED (airflow-noise)	2 SPEED (airflow-noise)	3 SPEED (airflow-noise)	4 SPEED * (airflow-noise)	5 SPEED * (airflow-noise)
GALAXY	C	288 m³/h - 52 dBA	416 m³/h - 61 dBA	559 m³/h - 69 dBA	---	647 m³/h - 73 dBA
GALAXY ISLAND	C	288 m³/h - 52 dBA	416 m³/h - 61 dBA	559 m³/h - 69 dBA	---	647 m³/h - 73 dBA
GETUP	A	260 m³/h - 43 dBA	428 m³/h - 58 dBA	530 m³/h - 62 dBA	630 m³/h - 66 dBA	750 m³/h - 67 dBA
GLASS OUT	A	235 m³/h - 53 dBA	315 m³/h - 54 dBA	425 m³/h - 61 dBA	---	560 m³/h - 65 dBA
GLIDE	B	240 m³/h - 48 dBA	365 m³/h - 55 dBA	610 m³/h - 68 dBA	---	---
HAIKU	A	155 m³/h - 34 dBA	295 m³/h - 47 dBA	375 m³/h - 51 dBA	560 m³/h - 58 dBA	690 m³/h - 63 dBA
HAIKU ISLAND	A	155 m³/h - 34 dBA	295 m³/h - 47 dBA	375 m³/h - 51 dBA	560 m³/h - 58 dBA	690 m³/h - 63 dBA
HIDDEN	D	240 m³/h - 46 dBA	360 m³/h - 55 dBA	464 m³/h - 64 dBA	581 m³/h - 69 dBA	---
HILIGHT-GLS H30	A	220 m³/h - 38 dBA	395 m³/h - 49 dBA	460 m³/h - 53 dBA	700 m³/h - 63 dBA	790 m³/h - 66 dBA
HILIGHT-GLS H16	A	235 m³/h - 49 dBA	445 m³/h - 64 dBA	570 m³/h - 69 dBA	680 m³/h - 73 dBA	720 m³/h - 75 dBA
HILIGHT-X H16	A	235 m³/h - 49 dBA	445 m³/h - 64 dBA	570 m³/h - 69 dBA	680 m³/h - 73 dBA	720 m³/h - 75 dBA
HILIGHT-X H30	A	110 m³/h - 31 dBA	415 m³/h - 58 dBA	510 m³/h - 63 dBA	620 m³/h - 67 dBA	780 m³/h - 72 dBA
IKONA LIGHT	A	275 m³/h - 49 dBA	400 m³/h - 57 dBA	560 m³/h - 64 dBA	---	710 m³/h - 69 dBA
ILLUSION H16	A	235 m³/h - 49 dBA	445 m³/h - 64 dBA	570 m³/h - 69 dBA	680 m³/h - 73 dBA	720 m³/h - 75 dBA
ILLUSION H30	A	220 m³/h - 38 dBA	395 m³/h - 49 dBA	460 m³/h - 53 dBA	700 m³/h - 63 dBA	790 m³/h - 66 dBA
INTEGRATA	D	125 m³/h - 52 dBA	224 m³/h - 61 dBA	288 m³/h - 67 dBA	---	---
INTERSTELLAR	A	165 m³/h - 36 dBA	209 m³/h - 53 dBA	336 m³/h - 54 dBA	---	384 m³/h - 56 dBA
IO AIR	A	230 m³/h - 42 dBA	325 m³/h - 50 dBA	510 m³/h - 60 dBA	---	650 m³/h - 66 dBA
JOY	B	288 m³/h - 51 dBA	432 m³/h - 61 dBA	581 m³/h - 69 dBA	---	713 m³/h - 73 dBA
JUNO	A	260 m³/h - 45 dBA	375 m³/h - 55 dBA	610 m³/h - 67 dBA	---	---
JUNO URBAN CAST	A	260 m³/h - 45 dBA	375 m³/h - 55 dBA	610 m³/h - 67 dBA	---	---
KREA LUX	D	135 m³/h - 52 dBA	185 m³/h - 61 dBA	336 m³/h - 73 dBA	---	---
KREA ST	D	110 m³/h - 52 dBA	206 m³/h - 64 dBA	272 m³/h - 71 dBA	---	---
LANE	B	255 m³/h - 49 dBA	400 m³/h - 58 dBA	550 m³/h - 65 dBA	---	650 m³/h - 68 dBA
LEAF	B	395 m³/h - 56 dBA	515 m³/h - 62 dBA	620 m³/h - 70 dBA	---	760 m³/h - 73 dBA
LEVER	B	240 m³/h - 46 dBA	336 m³/h - 54 dBA	603 m³/h - 67 dBA	---	---
LULLABY DUCT-OUT	A	220 m³/h - 38 dBA	395 m³/h - 49 dBA	460 m³/h - 53 dBA	700 m³/h - 63 dBA	790 m³/h - 66 dBA
LULLABY FILTERING	**	104 m³/h - 44 dBA	159 m³/h - 53 dBA	237 m³/h - 63 dBA	384 m³/h - 72 dBA	474 m³/h - 76 dBA
MAJESTIC NO DRIP	A	245 m³/h - 46 dBA	345 m³/h - 53 dBA	485 m³/h - 60 dBA	---	600 m³/h - 66 dBA
METEORITE	A	115 m³/h - 31 dBA	410 m³/h - 55 dBA	515 m³/h - 60 dBA	620 m³/h - 64 dBA	800 m³/h - 68 dBA
METEORITE ISLAND	A	115 m³/h - 31 dBA	410 m³/h - 55 dBA	515 m³/h - 60 dBA	620 m³/h - 64 dBA	800 m³/h - 68 dBA
MINI IO	A	240 m³/h - 48 dBA	320 m³/h - 50 dBA	590 m³/h - 63 dBA	---	---
NUANCE	A	230 m³/h - 49 dBA	330 m³/h - 53 dBA	440 m³/h - 62 dBA	---	580 m³/h - 65 dBA
PANDORA	A	208 m³/h - 45 dBA	288 m³/h - 49 dBA	496 m³/h - 59 dBA	---	669 m³/h - 67 dBA
PANDORA GME	C	240 m³/h - 58 dBA	336 m³/h - 60 dBA	581 m³/h - 71 dBA	---	713 m³/h - 72 dBA

* Booster time speeds

** Model not subject to compulsory energy certification.

LEARN MORE ABOUT PERFORMANCE

	ENERGY CLASS	1 SPEED (airflow-noise)	2 SPEED (airflow-noise)	3 SPEED (airflow-noise)	4 SPEED * (airflow-noise)	5 SPEED * (airflow-noise)
PEARL	**	180 m³/h - 55 dBA	265 m³/h - 63 dBA	335 m³/h - 67 dBA	---	400 m³/h - 70 dBA
PIX	A	250 m³/h - 44 dBA	358 m³/h - 53 dBA	445 m³/h - 60 dBA	---	610 m³/h - 65 dBA
PLAT	A	160 m³/h - 38 dBA	325 m³/h - 52 dBA	420 m³/h - 57 dBA	---	730 m³/h - 69 dBA
REEF A	A	255 m³/h - 48 dBA	365 m³/h - 57 dBA	500 m³/h - 64 dBA	---	600 m³/h - 69 dBA
REEF A ISLAND	A	255 m³/h - 48 dBA	365 m³/h - 57 dBA	500 m³/h - 64 dBA	---	600 m³/h - 69 dBA
RULES	A	160 m³/h - 40 dBA	415 m³/h - 58 dBA	445 m³/h - 60 dBA	---	700 m³/h - 71 dBA
SHEEN-S	A	275 m³/h - 52 dBA	385 m³/h - 59 dBA	495 m³/h - 65 dBA	---	650 m³/h - 71 dBA
SHINING	A	160 m³/h - 36 dBA	205 m³/h - 41 dBA	335 m³/h - 53 dBA	---	380 m³/h - 56 dBA
SIENNA	B	208 m³/h - 51 dBA	272 m³/h - 59 dBA	384 m³/h - 66 dBA	---	515 m³/h - 72 dBA
SIENNA URBAN	B	208 m³/h - 51 dBA	272 m³/h - 59 dBA	384 m³/h - 66 dBA	---	515 m³/h - 72 dBA
SKYDOME H16	A	235 m³/h - 49 dBA	445 m³/h - 64 dBA	570 m³/h - 69 dBA	680 m³/h - 73 dBA	720 m³/h - 75 dBA
SKYDOME H30	A	220 m³/h - 38 dBA	395 m³/h - 49 dBA	460 m³/h - 53 dBA	700 m³/h - 63 dBA	790 m³/h - 66 dBA
SKLOK	D	100 m³/h - 48 dBA	130 m³/h - 54 dBA	255 m³/h - 66 dBA	---	---
SLEEK 2.0	A	300 m³/h - 51 dBA	420 m³/h - 60 dBA	600 m³/h - 67 dBA	---	700 m³/h - 70 dBA
SLEEK 2.0 @	A	300 m³/h - 51 dBA	420 m³/h - 60 dBA	600 m³/h - 67 dBA	---	700 m³/h - 70 dBA
STONE	C	240 m³/h - 44 dBA	368 m³/h - 53 dBA	559 m³/h - 67 dBA	---	---
SUMMILUX	A	165 m³/h - 36 dBA	205 m³/h - 41 dBA	336 m³/h - 53 dBA	---	384 m³/h - 56 dBA
SUPER PLAT	A	175 m³/h - 37 dBA	325 m³/h - 50 dBA	415 m³/h - 57 dBA	600 m³/h - 65 dBA	740 m³/h - 70 dBA
TAMAYA HP	D	285 m³/h - 53 dBA	365 m³/h - 58 dBA	430 m³/h - 62 dBA	---	---
TANDEM	**	280 m³/h - 58 dBA	460 m³/h - 65 dBA	625 m³/h - 73 dBA	---	865 m³/h - 78 dBA
THIN	A	145 m³/h - 34 dBA	300 m³/h - 47 dBA	385 m³/h - 52 dBA	560 m³/h - 60 dBA	680 m³/h - 64 dBA
THIN ISLAND	A	145 m³/h - 34 dBA	300 m³/h - 47 dBA	385 m³/h - 52 dBA	560 m³/h - 60 dBA	680 m³/h - 64 dBA
TONDA	D	265 m³/h - 60 dBA	325 m³/h - 65 dBA	355 m³/h - 67 dBA	---	---
TRIBE A	A	255 m³/h - 48 dBA	365 m³/h - 57 dBA	500 m³/h - 64 dBA	---	600 m³/h - 69 dBA
TRIBE A ISLAND	A	255 m³/h - 48 dBA	365 m³/h - 57 dBA	500 m³/h - 64 dBA	---	600 m³/h - 69 dBA
TUBE PRO ISLAND	C	240 m³/h - 47 dBA	368 m³/h - 56 dBA	603 m³/h - 68 dBA	---	---
YIN	A	220 m³/h - 45 dBA	300 m³/h - 52 dBA	455 m³/h - 61 dBA	---	600 m³/h - 66 dBA

* Booster time speeds

** Model not subject to compulsory energy certification.

LEARN MORE ABOUT PERFORMANCE

	ENERGY CLASS	1 SPEED m³/h-dBA	2 SPEED m³/h-dBA	3 SPEED m³/h-dBA	4 SPEED m³/h-dBA	5 SPEED m³/h-dBA	6 SPEED m³/h-dBA	7 SPEED m³/h-dBA	8 SPEED m³/h-dBA	9 SPEED m³/h-dBA	BOOSTER 1* m³/h-dBA	BOOSTER 2* m³/h-dBA
NT FIT (Duct-out)	A	195 - 47	330 - 52	360 - 54	---	---	---	---	---	---	515 - 63	620 - 67
NT FLAME (Duct-out)	A	225 - 48	315 - 56	400 - 62	---	---	---	---	---	---	485 - 66	600 - 71
NT FLAME (Filtering)	A	185 - 53	300 - 63	380 - 68	---	---	---	---	---	---	460 - 72	550 - 77
NT LIBRA (Duct-out)	A	135 - 33	340 - 57	405 - 62	---	---	---	---	---	---	500 - 66	630 - 72
NT LIBRA (Filtering)	A	185 - 53	300 - 63	380 - 68	---	---	---	---	---	---	460 - 72	550 - 77
NT ONE (Duct-out)	A+	130 - 34	205 - 44	235 - 47	280 - 51	305 - 54	335 - 56	370 - 58	390 - 59	410 - 61	640 - 72	---
NT ONE (Filtering)	A+	105 - 40	170 - 50	200 - 53	235 - 57	260 - 59	290 - 62	320 - 64	340 - 65	360 - 67	545 - 77	---
NT PRIME (Duct-out)	A	200 - 43	320 - 57	400 - 61	---	---	---	---	---	---	485 - 66	620 - 72
NT PRIME (Filtering)	A	185 - 53	300 - 63	380 - 68	---	---	---	---	---	---	460 - 72	550 - 77
NT SWITCH (Duct-out)	A+	135 - 33	190 - 41	220 - 44	260 - 49	290 - 52	315 - 54	350 - 57	375 - 59	---	590 - 70	630 - 71
NT SWITCH (Filtering)	A+	110 - 39	160 - 48	190 - 51	230 - 55	255 - 58	280 - 60	310 - 62	330 - 64	---	540 - 75	550 - 76
NT Prime (Filtering)	**	175 - 54	336 - 69	384 - 71	---	---	---	---	---	---	400 - 72	422 - 73
NT Switch (Duct-Out)	A+	121 - 37	150 - 49	278 - 52	296 - 54	314 - 56	338 - 58	368 - 59	374 - 60	---	580 - 70	620 - 72
NT Switch (Filtering)	**	134 - 43	174 - 48	230 - 55	243 - 56	288 - 60	306 - 62	326 - 63	349 - 64	---	363 - 65	536 - 74

* Booster time speeds
** Model not subject to compulsory energy certification.

LEARN MORE

	REDUCTION 150/125	ODOUR FILTER ALERT	GREASE FILTER ALERT	NO RETURN VALVE
ACUTA	---	√	√	√
ADÉLE	√	√	√	√
ADÉLE ISLAND	√	√	√	√
ALPHA	---	√	√	√
APLOMB	---	√	√	√
AQUAVITAE				
ASCENT	---	√	√	√
ASCENT URBAN	---	√	√	√
BELLE	---	√	√	
BIO	---	√	√	√
BIO ISLAND	---	√	√	√
BLOOM	---	√	√	√
BLOOM-S	---	√	√	√
BOXIN	√	---	---	---
BOXIN HE	√	---	---	√
BOXIN LUX	√	---	---	---
BOXIN NO DRIP	√	√	√	
CELESTIAL	---	√	√	---
CLAIRE				
CLOUD SEVEN	---	√	√	---
CRUISE	---	√	√	√
DIVA	---	√	√	---
DOLCE	√	√	√	√
EASY	---	√	√	---
ELIBLOC HT	---	---	---	---
ELIBLOC LUX	---	√	√	√
ELITE 14	---	---	---	√
ELITE 35	---	√	√	√
ERA STD	---	---	---	√
ERA LUX	---	---	---	√

	REDUCTION 150/125	ODOUR FILTER ALERT	GREASE FILTER ALERT	NO RETURN VALVE
ERA HE	---	---	---	√
FILM	---	√	√	√
FLOW	---	√	√	
GALAXY	---	√	√	√
GALAXY ISLAND	---	√	√	√
GETUP	---	√	√	---
GLIDE				
GLASS OUT	---	√	√	√
HAIKU	√	√	√	√
HAIKU ISLAND	√	√	√	√
HIDDEN				
HILIGHT-GLS H30	---	√	√	---
HILIGHT-GLS H16	---	√	√	---
HILIGHT-X H16	---	√	√	---
HILIGHT-X H30	---	√	√	---
IKONA LIGHT	---	√	√	---
ILLUSION H16	---	√	√	---
ILLUSION H30	---	√	√	---
INTEGRATA				
INTERSTELLAR	---	√	√	---
IO AIR	---	√	√	---
JOY	√	√	√	---
JUNO	---	---	---	---
JUNO URBAN	---	---	---	---
KREA LUX	---	---	---	---
KREA ST	---	---	---	---
LANE	√	√	√	√
LEAF	---	√	√	√
LEVER	---	---	---	---
LULLABY DUCT-OUT	---	√	√	

LEARN MORE

	REDUCTION 150/125	ODOUR FILTER ALERT	GREASE FILTER ALERT	NO RETURN VALVE
LULLABY FILTERING	---	√	√	
MAJESTIC NO DRIP	---	√	√	√
METEORITE	---	√	√	√
METEORITE ISLAND	---	√	√	√
MINI IO	---	---	---	√
NUANCE	---	√	√	---
PANDORA	---	√	√	---
PANDORA GME	---	√	√	---
PEARL	---	---	---	---
PIX	---	√	√	---
PLAT	---	√	√	---
REEF A	---	√	√	√
REEF A ISLAND	---	√	√	√
RULES	---	√	√	√
SHEEN-S	---	√	√	√
SHINING	---	√	√	---
SIENNA	---	√	√	---
SIENNA URBAN	---	√	√	---

	REDUCTION 150/125	ODOUR FILTER ALERT	GREASE FILTER ALERT	NO RETURN VALVE
SKLOCK	---	---	---	---
SKYDOME H16	---	√	√	---
SKYDOME H30	---	√	√	---
SLEEK 2.0	√	√	√	√
SLEEK 2.0 @	√	√	√	---
STONE	---	---	---	---
SUMMILUX	---	√	√	---
SUPER PLAT	---	√	√	---
TAMAYA HP	---	---	---	---
THIN	---	√	√	√
THIN ISLAND	√	√	√	√
TONDA	√	---	---	---
TRIBE A	---	√	√	√
TRIBE A ISLAND	---	√	√	√
TUBE PRO ISLAND	√	---	---	√
TANDEM	---	√	√	---
YIN	---	---	---	√

GREASE FILTERS

Aluminium Grease Filter

KIT0010805



Layered aluminum grease filter (GFA). This filter is the most common on the market, also because, thanks to its size it can be easily washed by hand, or in the dishwasher.

Professional Baffle Filter

KIT0010804



All steel grease filter that gives the product a typical commercial hood look. Thanks to the multiple steel layers, this filter has a high grease capturing capacity.

Professional Stainless Steel Grease Filters

KIT0010806

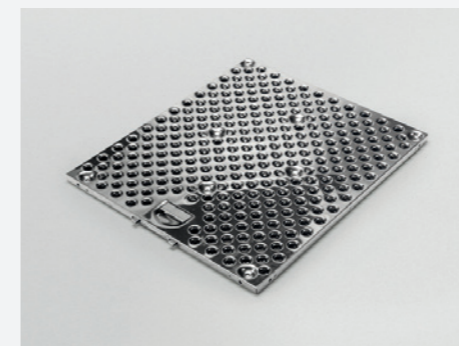

Grease filter with the first layer in steel and a microperforated back metal sheet, easily washable and with high grease capturing capacity.

Stainless Steel Grease Filter

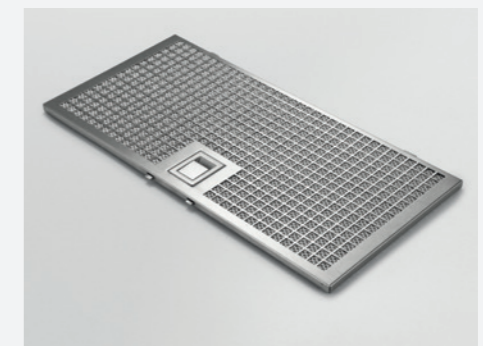

Layered aluminum grease filter (GFI). The first aesthetic steel layer gives it a professional look, while still maintaining its easy washability.

ODOUR FILTERS

Charcoal Filter



The traditional odour filter, made up of a mix of activated carbons, loses its efficiency through use and has an average life of 3-6 months.

Revolution Filter



This odour filter with very high efficiency level >82% is able to be regenerated and is capable of lasting up to 3 years in comparison to standard filters which have a typical effective life of 6 months. To maintain such characteristics, the filter must be washed every 2 to 3 months with hot water and mild soap, or in the dishwasher at 65°C. and dried in the oven for 10 minutes at 100°C.

Standard and High Performance Regeneratable Filters



These filters can be regenerated in the same way as the revolution filter. The standard filter has an efficiency of up to 60% and the high performance up to 80%.

Ceramic Filter



The modular ceramic filter gives very high odour absorption efficiency and has very high mechanical strength. As a result it can be thermally regenerated in the oven every 2 to 3 months at 200°C for 45 minutes for up to 5 years.

ODOUR FILTERS

	FILTER CODE	FILTER TYPE
ACUTA	CFC0140343	Charcoal
ADÉLE	CFC0141529A	Charcoal
	CFC0141725A	Regeneratable
ADÉLE ISLAND	CFC0141529A	Charcoal
	CFC0141725A	Regeneratable
ALPHA	CFC0141529A	Charcoal
	CFC0141725A	Regeneratable
APLOMB	CFC0140343	Charcoal
AQUAVITAE	CFC0157821	Charcoal
ASCENT	CFC0140343	Charcoal
	CFC0162221	Regeneratable
ASCENT URBAN	CFC0140343	Charcoal
	CFC0162221	Regeneratable
BELLE	CFC0140053	Revolution charcoal
	CFC0140090	Regeneratable
BIO	CFC0140091	Revolution charcoal
BIO ISLAND	CFC0140091	Revolution charcoal
BLOOM	CFC0140343	Charcoal
	CFC0162221	Regeneratable
BLOOM-S	CFC0140343	Charcoal
	CFC0162221	Regeneratable
BOXIN	CFC0141497	Charcoal
BOXIN HE LUX	CFC0140343	Charcoal
	CFC0162221	Regeneratable
BOXIN NO DRIP	CFC0140343	Charcoal
	CFC0162221	Regeneratable

	FILTER CODE	FILTER TYPE
CELESTIAL	CFC0140384	Regeneratable
CLAIRE	CFC0141529	Charcoal
	CFC0141725	Regeneratable
CRUISE	CFC0141529A	Charcoal
	CFC0141725A	Regeneratable
DIVA	CFC0140053	Revolution charcoal
	CFC0140090	Regeneratable
DOLCE	CFC0140426	Regeneratable
EASY	CFC0140088	Regeneratable
ELIBLOC HT ELIBLOC LUX	CFC0140122	Charcoal
ELITE 14	CFC0141571	Charcoal
ELITE 35	CFC0140075	Charcoal
ERA STD	CFC0141571	Charcoal
ERA LUX	CFC0141571	Charcoal
ERA HE	CFC0141571	Charcoal
FILM	CFC0140343	Charcoal
FLOW	CFC0140384	Regeneratable
GALAXY	CFC0141529A	Charcoal
	CFC0141725A	Regeneratable
GALAXY ISLAND	CFC0141529A	Charcoal
	CFC0141725A	Regeneratable
GETUP	KIT0166432	Regeneratable HP
	KIT0166444	Regeneratable

ODOUR FILTERS

	FILTER CODE	FILTER TYPE
GLASS OUT	CFC0140343	Charcoal
	CFC0162221	Regeneratable
GLIDE	CFC0149389	Regeneratable
HAIKU	CFC0141529A	Charcoal
	CFC0141725A	Regeneratable
HAIKU ISLAND	CFC0141529A	Charcoal
	CFC0141725A	Regeneratable
HIDDEN	CFC0140394	Regeneratable
IKONA LIGHT	CFC0140343	Charcoal
INTEGRATA	F00428	Charcoal
INTERSTELLAR	CFC0140053	Revolution charcoal
	CFC0140090	Regeneratable
JOY	CFC0141529A	Charcoal
	CFC0141725A	Regeneratable
JUNO	CFC0140088	Regeneratable
JUNO URBAN	CFC0140088	Regeneratable
KREA	CFC0140064	Charcoal
LANE	CFC0140343	Charcoal
	CFC0162221	Regeneratable
LEAF	CFC0140088	Regeneratable
LEVER	CFC0140343	Charcoal
	CFC0162221	Regeneratable
MAJESTIC NO DRIP	CFC0140343	Charcoal
	CFC0162221	Regeneratable
METEORITE	CFC0140091	Revolution charcoal
METEORITE ISLAND	CFC0140091	Revolution charcoal
MINI IO	CFC0140423	Regeneratable

	FILTER CODE	FILTER TYPE
NUANCE	CFC0140343	Charcoal
	CFC0162221	Regeneratable
IO AIR	CFC0140343	Charcoal
	CFC0162221	Regeneratable
PANDORA	CFC0142324	Charcoal
PEARL	CFC0141725A	Regeneratable
PIX	KIT0147175	Regeneratable
PLAT	CFC0140423	Regeneratable
REEF A	CFC0141529A	Charcoal
	CFC0141725A	Regeneratable
REEF A ISLAND	CFC0141529A	Charcoal
	CFC0141725A	Regeneratable
RULES	CFC0166361	Regeneratable
SIENNA	CFC0140384	Regeneratable
SIENNA URBAN	CFC0140384	Regeneratable
SKLOCK	CFC0141563	Charcoal
SHEEN-S	CFC0140343	Charcoal
SHINING	CFC0140053	Revolution charcoal
	CFC0140090	Regeneratable
SLEEK 2.0	CFC0140343	Charcoal
	CFC0162221	Regeneratable
SLEEK 2.0 @	CFC0140343	Charcoal
	CFC0162221	Regeneratable
STONE	CFC0141529A	Charcoal
	CFC0141725A	Regeneratable

ODOUR FILTERS

	FILTER CODE	FILTER TYPE
SUMMILUX	CFC0140053	Revolution charcoal
	CFC0140090	Regeneratable
SUPER PLAT	CFC0140423	Regeneratable
TAMAYA HP	CFC0140124	Charcoal
TANDEM	CFC0140384	Regeneratable
THIN	CFC0141529A	Charcoal
	CFC0141725A	Regeneratable
THIN ISLAND	CFC0141529A	Charcoal
	CFC0141725A	Regeneratable
TONDA	CFC0140124	Charcoal
TRIBE A	CFC0141529A	Charcoal
	CFC0141725A	Regeneratable
TRIBE A ISLAND	CFC0141529A	Charcoal
	CFC0141725A	Regeneratable
TUBE PRO ISLAND	CFC0140423	Regeneratable
YIN	CFC0141737	Regeneratable

	FILTER CODE	FILTER TYPE
NIKOLATESLA FIT	KIT0167755	Ceramic
NIKOLATESLA FLAME	KIT0120952A	Ceramic
NIKOLATESLA LIBRA	KIT0120952A	Ceramic
NIKOLATESLA ONE	KIT0120952A	Ceramic
NIKOLATESLA PRIME	KIT0120952A	Ceramic
NIKOLATESLA SWITCH	KIT0120952A	Ceramic

* see the dedicated section for the ceiling model carbon filter kits

REMOTE MOTORS

GME22 MOTOR

Airflow 1420 m³/h
Absorption Tot. 200 W
Duct size 150 mm

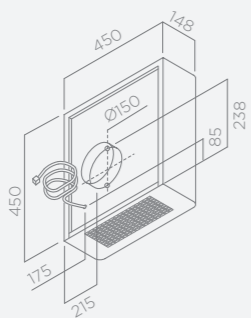

PRF0006212A
Available for
PANDORA

GME88 MOTOR

Airflow 1495 m³/h
Absorption Tot. 250 W (50Hz)
390 W (60Hz)
Duct size 150 mm



PRF0046491A
Available for
PANDORA

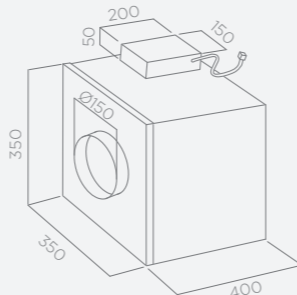

GME11 MOTOR

Airflow 670 m³/h
Absorption Tot. 135 W
Duct size 150 mm

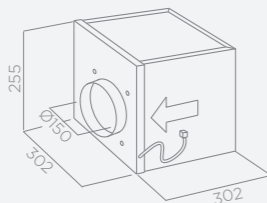
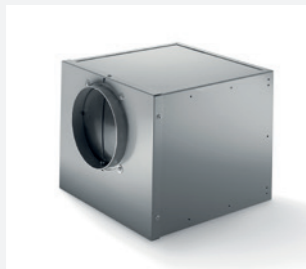

PRF0171141
Available for
LANE

GME HE MOTOR

Airflow 551 m³/h
Absorption Tot. 171 W
Duct size 150 mm

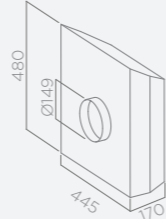

PRF0171142
Available for
LANE

GME EXTERNAL WALL

Airflow 1100 m³/h
Absorption Tot. 150 W
Duct size 150 mm

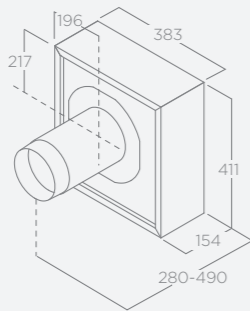

KIT0147880
Available for
HILIGHT / ILLUSION /
SKYDOME

GME EXTERNAL ROOF TILED

Airflow 1200 m³/h
Absorption Tot. 200 W
Duct size 150 mm

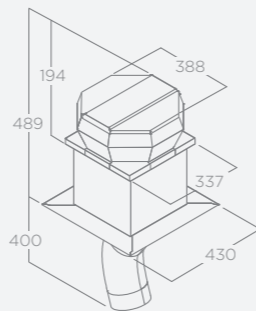
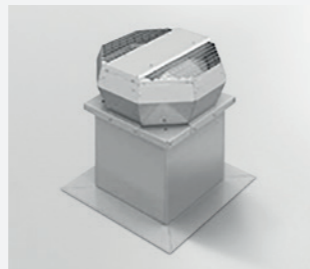

KIT0147881
Available for
HILIGHT / ILLUSION /
SKYDOME

GME EXTERNAL INCLINED ROOF

Airflow 1200 m³/h
Absorption Tot. 200 W
Duct size 150 mm

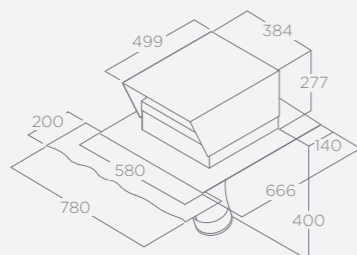

KIT0147882
Available for
HILIGHT / ILLUSION /
SKYDOME

GME INTERNAL INLINE

Airflow 2150 m³/h
Absorption Tot. 250 W
Duct size 150 mm
(264mm motor)

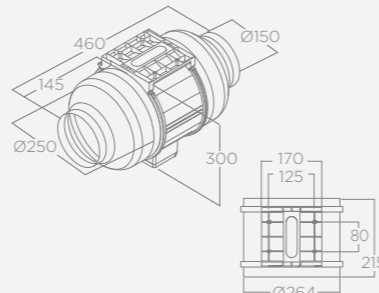

KIT0147879
Available for
HILIGHT / ILLUSION /
SKYDOME

THE IMPORTANCE OF THE HOOD IN THE KITCHEN

The extractor hood is an essential tool in the kitchen, helping to improve air quality and maintain a healthy environment. Combustion fumes, unpleasant smells, odours and cooking vapours are unpleasant and annoying and can also damage furniture and wall coverings. It is, therefore, important to ensure effective, easy-to-use and quiet extraction. The hood is now used not only as a basic **extractor unit**, but also as a **light source** to illuminate just the hob or more generally and can also be a focal design point in the kitchen. The numerous models and finishes available allow you to choose the perfect hood for the design of your kitchen: whether it is minimal and linear or a statement, signature piece, the hood today has become a central element in our kitchens.

WHICH HOOD SHOULD I CHOOSE?

It can be difficult to find the best choice among the many models on offer. To find the hood that best suits your space, personal taste and lifestyle, you should consider several key factors: correct extraction power, type of installation and kitchen design. For the best air removal performance, the hood must offer the **right extraction power**. Take a look at the size of your kitchen and your cooking habits. With a simple calculation, it is possible to define the ideal flow rate for each room: just multiply the room volume by 10. **Ease-of-use and silence** are another two important variables that will help you achieve the best user experience.

The **type of installation** is essential in narrowing the field and finding the category you need for your kitchen.



BUILT-IN

The hood is built into the cabinet, disappearing from view.



WALL-MOUNTED

The kitchen is positioned against the wall with the hob adjacent to the wall. Wall-mounted hood.

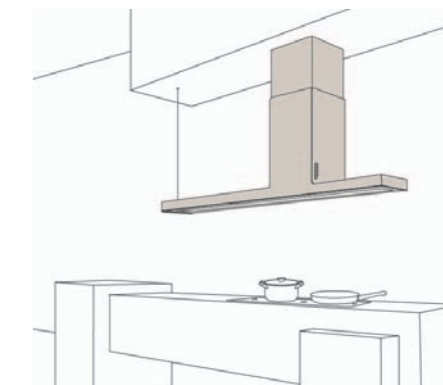

ISLAND

The kitchen is positioned in the centre of the room with the hob away from the wall. Ceiling-mounted hood.



CORNER

The kitchen is laid out between two walls of the room and the hob is positioned close to the corner. Install the hood between adjacent walls.



CEILING

The kitchen is positioned either in the centre of the room or against the wall. The hood acts as both a light and extractor and is installed in the false ceiling.

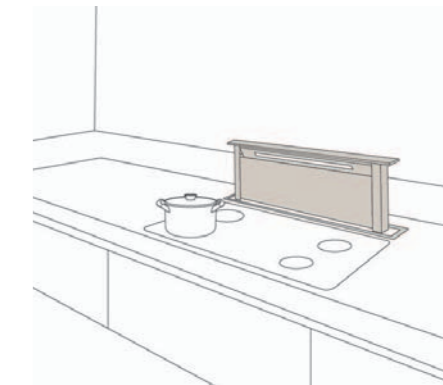

DOWNDRAFT

The hob is positioned away from the wall, on a peninsula counter or in the centre of the room. Install the hood directly on the top.

THE IMPORTANCE OF THE HOOD IN THE KITCHEN

**SUSPENDED**

Install the hood on the ceiling, suspended like a pendant light.

**EXTRACTOR HOB**

The hood is integrated into the hob. Extraction from below

HOW IS IT INSTALLED?

Perfect hood operation is ensured by correct installation, guaranteed by specialised personnel. Assembly and maintenance vary according to the two types of hood: extractor and filter. Many Elica models are designed to work in both versions. Before starting installation of your hood, bear in mind these simple, basic rules:

- Follow all the steps indicated in the instruction booklet;
- For duct-out installations connect the extractor hood to the outside using a dedicated pipe with the correct diameter usually 150mm: the shorter length and the fewer the bends guarantee the better the performance and the quieter the hood will be.

- The main cause of a cooker hood not working correctly is faulty installation using either too small ducting or ducting that is too long or has multiple bends. The longer the duct and the more bends the more the airflow will be reduced and the noise level increased.
- Follow the minimum distance from the hob indicated in the installation guide that comes with it and the instructions provided by the hob manufacturer which may require a greater distance to avoid damage to the operational parts and protect personal safety.
- Ensure that the location of the electrical outlet is close to the product for connection;
- In case of difficulty, request the intervention of a specialised technician.

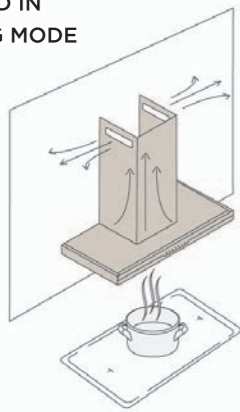
HOOD INSTALLED IN RE-CIRCULATING MODE

The filter hood eliminates fumes and unpleasant odours via dedicated filters and returns clean air to the kitchen. This type of hood is suitable in situations without no external evacuation hole.

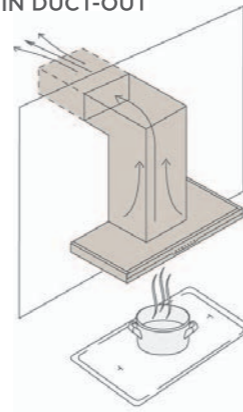
HOOD INSTALLED IN DUCT-OUT MODE

The extractor hood expels the air outside the home. It is the most common type as it guarantees high performance, high flow rate and minimum noise.

MAINTENANCE

To ensure that your hood lasts for a long time and continues to work correctly, the first step is to keep the filtering system in good condition.

**Filter hoods feature two types of filter:**

The **grease filter** which removes the grease from the air given off during cooking and the **odour filter**. Both must be regularly cleaned and replaced to ensure the very best performance.

- The grease filter protects your hood by trapping grease particles. The grease filter can be made of aluminium or stainless steel and requires periodic cleaning by hand with a neutral detergent or in the dishwasher at a low temperature (*).

- The odour filter with activated carbon, installed on filter hoods, captures and traps odour particles in the air. Remember to replace it every 3-4 months. Long-life odour filters, on the other hand, last longer. They can, in fact, be regenerated and washed, dried and replaced every 2-3 years. A few simple, minor precautions are all it takes to keep your hood hygienic and working efficient over time.

(*) Always check how to wash the filter in the product instruction booklet

ENERGY LABEL

The Energy Label constitutes a fundamental tool for choosing the most suitable extractor hood for the user's needs. The label provides instant information on energy consumption and the level of efficiency of the product's performances.

Each page of our catalogue contains a symbol indicating the energy class of the product presented.

For obtaining detailed information on each version of the desired model, including all the parameters appearing on the energy label, proceed as follows:

- Identify the **product code** of the relevant model
- Visit the website **www.elica.com** and go to the DOWNLOADS section of the ASSISTANCE page, insert the product code in the search field and download the PDF document (Product Fiche) listing all the product characteristics, as per EU regulations no. 65/2014 and 66/2014.

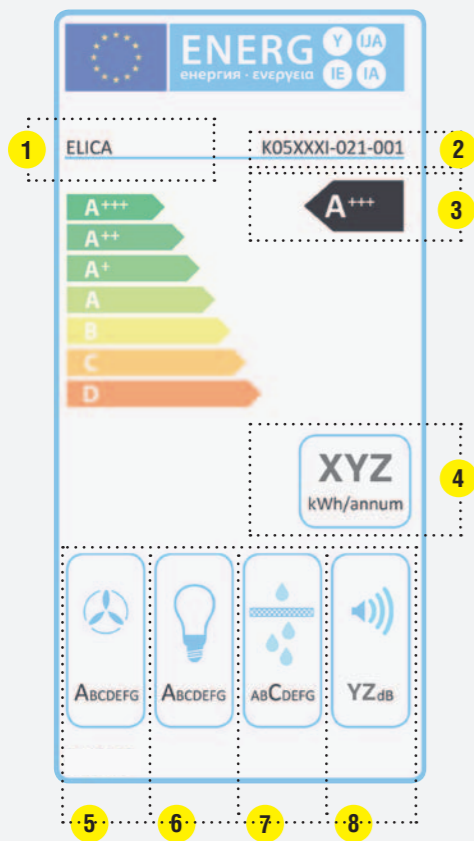

- 1 SUPPLIER NAME OR BRAND.
- 2 MODEL IDENTIFICATION CODE.
- 3 ENERGY EFFICIENCY CLASS
A/A+/A++/A+++ Maximum efficiency - D Minimum.
- 4 ESTIMATED ANNUAL ENERGY CONSUMPTION
For standard use
- 5 FLUID DYNAMIC EFFICIENCY CLASS
Indicates the efficiency with which the hood is able to extract vapours through cooking
A Maximum efficiency - G Minimum.
- 6 LIGHTING EFFICIENCY CLASS
Indicates the efficiency with which the hood is able to illuminate the cooker hob
A Maximum efficiency - G Minimum.
- 7 GREASE FILTERING EFFICIENCY CLASS
Indicates the efficiency with which the hood filters grease generated through cooking
A Maximum efficiency - G Minimum.
- 8 NOISE LEVEL
Indicates the maximum noise level generated by the product during normal use

All rights are reserved. Any form of total or partial reproduction of catalogue is strictly forbidden.

The printing process do not always permit a faithful reproduction of tones and materials of originals.

Elica may at any time modify the specifications and details of the products present in the catalogue.

D R Kitchen Appliances Ltd
2 Alpha Road, Aldershot
Hampshire GU12 4RG
t: 01252 351111
e: sales@drcookerhoods.co.uk
www.elica.co.uk

Twitter: @elicahoods
Facebook: elicacookerhoods
Pinterest: elica hoods
Houzz



www.elica.com